

Vol. 20 No. 6
February 11, 2022

f **FREE** Every Friday
www.hawkeyetrader.com

YOUR HAWKEYE TRADER

Phone: 641-675-3971 • Fax: 888-203-9720 • E-Mail: ads@hawkeyetrader.com

BUILDING PACKAGES



- Pole Barns
- Garages
- Shouses
- Lumber
- Metal Rollforming

Commercial & Residential



Give Us A Call For All Your Building Needs

641-664-3990

awmetal.net

BUYERS & SELLERS WANTED

NEXT AUCTION SAT., MARCH 5TH, 2022

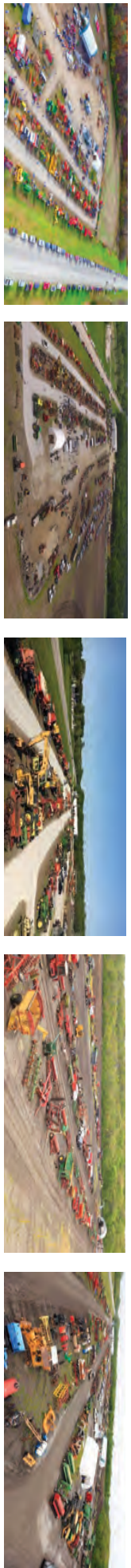

Join us on facebook!



2022 CONSIGNMENT AUCTION

Shay Esbeck 660-605-0839 | Barney Esbeck 660-605-0841 | Justin Harlow 660-605-2346

HAULING AVAILABLE • LIVE & ONLINE BIDDING • NATIONWIDE ADVERTISING • CONSIGN NOW!
Band Equipment Sales.com GALLATIN | MISSOURI

BUY | SELL | TRADE | EVERY DAY



UPCOMING AUCTION CALENDAR

American Legion Real Estate Online Auction
Brocket, ND | Closes: February 15 at 10AM

Erickson/Andersen Farm Equipment Online Auction
Glenville, MN | Closes: February 17 at 1PM

Rick Partin Trucking & Hotshot Realignment Online Auction
Sidney, MT | Closes: February 17 at 1PM

Weckerly Farms Equipment Update Online Auction
Hurdsville, ND | Closes: February 21 at 12PM

Richard Farm Retirement Online Auction
Horace, ND | Closes: February 22 at 12PM

Quality Tested Hay Online Auction
Litchfield, MN | Closes: February 22 at 12PM

Crawford County, WI Land & Home Auction - 3 Tracts
Gays Mills, WI | February 22 at 1PM

Steffes Online Auction
All Locations | Closes: February 23 at 10AM

Daniels County, MT Land Online Auction - 637± Acres
Richland, MT | Closes: February 23 at 12PM

Mitchell County, IA Land Auction - 77± Acres
Orchard, IA | February 24 at 11AM

Zavoral Family Farmland Online Auction - 160± Acres
McLeod County, MN | Closes: February 24 at 1PM

Darwin Mfg. & Turbo Service Online Auction
Darwin, MN | Closes: February 24 at 7PM

Bassen Farm Retirement Online Auction
Lamoure, ND | Closes: March 2 at 7PM

McLeod County, MN Tillable Land Online Auction
Silver Lake, MN | Closes: March 3 at 10AM

Walsh & Ramsey County, ND Land Online Auction
Lawton, ND | Closes: March 8 at 12PM

Quality Tested Hay Online Auction
Litchfield, MN | Closes: March 8 at 12PM

Grain Storage & Handling Online Auction
Atwater & Lakefield, MN | Closes: March 8 at 1PM

Steffes Truck & Transportation Online Auction
Mt. Pleasant, IA | Closes: March 8 at 1PM

Multi-Party Construction Equipment Online Auction
Mt. Pleasant, IA | Closes: March 8 at 3PM

Steffes Online Auction
All Locations | Closes: March 9 at 10AM

East Grand Forks Area Land Online Auction - 64± Acres
East Grand Forks, MN | Closes: March 9 at 12PM

More auctions listed at SteffesGroup.com

20' & 40' Storage Containers
Starting at \$1,895
For Sale or Rent

Dry & Mouse Proof

ABC Portable Storage
Delivery Available
563-299-2901

TRUE MODULARS
30 To 60 Day Delivery Available,
3 And 4 Bedroom
573-657-7040
www.chateauhomes.net

AG RELATED
FOR SALE: 2012 JD 1990 CS Air Drill, 35 Ft., 15 Inch Spacing, Low Acres, Purchased New.
641-208-0424 2-25

FOR SALE: 1st And 2nd Cutting Of Alfalfa And Grass Mix Round Bales, Net Wrapped, No Rain, \$70.
515-669-0704 2-18

FOR SALE: Big Round Bales Dry Hay Wrapped In Plastic, No Rain, First And Second Cutting, Alfalfa/Clover/Grass Mix, 200 Bales, \$35-\$70 A Bale.
641-722-3002 2-11

★★★★★
5-STAR SPRAY FOAM INC.
BROOKLYN MONTEZUMA
We Now Offer CONCRETE RAISING & LEVELING
Open Cell & Closed Cell Foam
Call or Email Craig
641-328-4163
fivestarsprayfoam@gmail.com
NEW CONSTRUCTION, REMODELS, POLE BARNs
CRAWL SPACES, ATTICS & MORE
Free Estimates • Fully Insured
WWW.5STARSprayFoam.COM

DES MOINES DIESEL INC
Servicing All Your Diesel Fuel Injection Needs
Pumps, Nozzles & Turbos

Ag & Truck Performance Parts
1-800-475-6086 • 515-265-7318
3211 Delaware Ave Des Moines, IA 50313
1 Blk E. of the ADM Soybean Plant

FOR SALE: 24 Ft x 5 Ft Free-Standing Cattle Panels, Weighing 600 Lbs Each, Fastener Chains Included. Located in Troy, IA.
641-680-0892 TFN

FOR SALE: 100 Orchard Grass, 50 Brome, 40 Alfalfa, 100 Straw In Big Square Bales. Also 200 Straw In Big Round Bales. All In Barn Near Cairo, MO. Please Call For Price.
573-470-0077 2-11

319.385.2000 | Steffes Group, Inc., 2245 East Bluegrass Road, Mt. Pleasant, IA

KARS, INC OF PLEASANT HILL

www.kars-inc.com

5701 E. University
Pleasant Hill, IA
515-564-0937



2010 Chevy Avalanche LTZ
4WD, 5.3 V8, Loaded, Leather, 136K
\$18,995



2012 GMC Canyon SLE
4WD, Crew Cab, Well Equipped, 109K
\$18,995



2014 Ford Escape SE
4 Cyl, Auto, Full Power, 129K
\$11,995



2016 Ford Explorer XLT
4WD, V6, Auto, Leather, Full Power, 3rd Row Seating, 85K
\$22,995



2014 Jeep Wrangler Sport
4x4, V6, Auto, CD/MP3, 87K Miles
\$27,995



2007 Toyota FJ Cruiser
4WD, V6, Auto, Nicely Equipped, 142K
\$18,995



2015 Subaru Forester 2.5i Premium
4 Cyl, Full Power, Sunroof, 124K
\$15,995



2012 Nissan Frontier SV
4WD, 4 Cyl, Auto, Ext Cab, 4 Dr, Keyless Entry, 100K
\$17,995



2016 Ford Fusion SE
4 Cyl, Auto, Full Power, Sunroof, Backup Camera, 133K
\$11,995



2013 Jeep Wrangler Sahara
4x4, V6, Auto, Loaded, 123K
\$28,995



2011 Toyota Highlander Base
4WD, V6, Auto, Full Power, 3rd Row Seating, 78K
\$19,995



2012 Honda Insight LX
Gas/Electric Hybrid, 130K
\$7,995



2013 Chevy Malibu 1LT
4 Cyl, Auto, Lots of Equipment, 116K
\$12,995



2014 Honda Pilot EXL
4WD, V6, Auto, Loaded, Leather, 3rd Row Seating, 114K
\$18,995



2016 Chevy Suburban K1500 LTZ
4WD, 5.3 V8, Auto, Loaded, Leather, 3rd Row Seating, 113K
\$38,995



2019 Chevy 1500
Crew Cab, LTZ, 4x4,
Fully Loaded w/All the Options,
Local Trade, 41K Miles
\$49,500



2018 Ford F150
Crew Cab, 4x4, Chrome Pkg,
Htd Cloth, Remote Start,
Navigation, 29K Miles
\$43,900



2017 Chevy Silverado 3500
Crew Cab, 4x4, LTZ, 6.6 Diesel,
Hydra Bale Bed, LOTS OF OPTIONS,
89K Miles
\$57,500



2012 Toyota Camry LE
Fully Equipped,
Power Sunroof, 1-Owner,
Only 83K Miles
\$13,900



2011 Ford Explorer XLT
4WD, Heated Leather,
3rd Row Seat,
Local Trade
\$8,900



2002 Ford Explorer XLT
4x4, Full Power,
Near New Tires, Local Trade,
133K Miles
\$4,900

CHARITON FORD



Call Karl Stone • Mike Scieszinski
CELL: 641-774-6735 641-774-2586
Chariton, Iowa • www.charitonford.com



BUY OF THE WEEK!
2004 FLHTC
Looks & Runs Good

NO DOC FEES! **\$5,995**

G&C Cycle
Chariton, IA • 888-475-2243
www.cc-cycle.com

AUTOMOTIVE

FOR SALE: 2011 Ram 1500 Big Horn, 4x4, Quad Cab, 5.7 V8, Auto Full Power Tow, Sharp, 132K, 641-820-0348 2-18

FOR SALE: 4 BFGoodrich Tires LT285/60R18, 5/32 Tread, \$25 Each, Call. 319-931-3838 2-18

FOR SALE: 1994 Jaguar Vanden Plas XJ6, Maroon, 6 Cyl Auto, Leather, Moonroof, 54K Miles, \$3,000, 641-203-9299 TFN

ATTN TRUCK OWNERS: Rhino Linings Offers You The Worlds Number One Sprayed In Truck Bedliner. Also Works On Livestock Tanks, Creep Feeders, Horse Trailers, Etc. Call For An Appointment & More Info. 641-799-5672 TFN

LIVESTOCK

FOR SALE: 21 Outstanding Simmental And Sim-Angus Cows. Bred To Top Bulls Of The Breed To Start Calving 2-15-22. Average Age Coming 6 Yrs. Preg-Checked In 3rd Stage. Average 1400 lbs. Papers Available. Drake Simmental. Centerville, Iowa. 641-895-9422 2-11

BULLS FOR LEASE: Over 70 Registered Angus & Hereford To Choose From. 90 Day Lease \$900. Trucking Available At Extra Charge. Kingdom City, MO. 573-999-3197 TFN

FOR SALE: Quality Holstein Angus Cross Feeder Calves On Kalmbach Feed, Complete Vaccination Program, Trailer Size Loads, For More Info Or Pictures. 814-229-2401 2-25

MISC

BUILDING MATERIALS FOR SALE: 2X4'S, Half Inch Plywood And OSB. 515-290-2901 2-25

INSTALLING: Metal And Shingle Roof. Serving The Tri-State Area, Call For Free Quote. 660-730-0233 2-18

FOR SALE: Used (47) 50 Ft. Trusses; 120 Sheets Of 27 Ft. Long Steel Siding/Roofing Panels; 140 Sheets 20 Ft. Long X 3 Ft. Wide Corrugated Plastic Ceiling Panels; (200) 20 Ft. 2x4's. Best Offer. 641-660-6838 2-18

CUSTOM LOG SLABBING SERVICES: No Log is Too Big! Maximum Log Capacity 90 Inches Diameter by 27 Foot Long. Jaguar Lumber 641-664-2080 TFN

POST FRAME BUILDINGS

- Best Quality
- Great Prices
- Great Service



www.lancasterlumber.com

LANCASTER LUMBER, INC
800-424-5071 • LANCASTER, MO

Want to Buy Walnut

SERVING ALL OF IOWA

HINDMAN LOGGING

641-485-9071
Bonded & Insured

Timber Paid in Full Before Cutting

Virtual Online Auction - Bid @ www.SullivanAuctioneers.com

Appanoose County, Iowa LAND AUCTION

WEDNESDAY, FEBRUARY 23, 2022 @ 10:00 A.M.



210.64 TAXABLE ACRES
2 TRACTS

The Wakefield farm is located in Sections 22 & 23, Johns Township, Appanoose County, Iowa (just east of the small town of Plano, Iowa).

Make plans now for this upcoming Appanoose County, Iowa land auction. Tract 1 offers highly productive Kniffin, Appanoose & Olmitz soils currently in row crop and hay production. Tract 2 is currently in hay production. We urge you to take a look at these well maintained farms that feature attractive recreational and hunting opportunities. You will not want to miss this auction.

WAKEFIELD FAMILY FARM

Representing Attorney: Rick Lynch | Lynch Law Office
207 S Washington St, Bloomfield, IA 52537 | (641) 664-3188

AUCTION MANAGER: John Probasco (641) 856-7355

SULLIVAN AUCTIONEERS, LLC • TOLL FREE (844) 847-2161
www.SullivanAuctioneers.com • IL Lic. #444000107

HOOVER'S
RUDD HATCHERY IOWA

SUMMER CHICK PRE ORDER

CHICKS WILL BE ORDERED & DELIVERED TO QUALITY PLUS FEEDS!

Is Finally Here!

Order Your **SUMMER BROILERS NOW!**

QUALITY PLUS FEEDS

2033 LOCUST STREET, SAINT PAUL, IA
(319) 469-3167
WWW.QUALITYPLUSFEEDING.COM



Specializing in Roll Forming

• Pole Barn Packages

• Re-Roofing

Full Line of Building Materials



MILLER'S METAL SUPPLY

1187 Orange Ave, Kalona
319-646-1103 vm

Bring In Your Plans for a Free Estimate

WHAT IS DREDGING???

DREDGING IS A PROCESS USED TO REMOVE ACCUMULATED SEDIMENT FROM THE BOTTOM, AND IN SOME CASES, THE BANKS OR SIDES OF A RIVER, LAKE, STREAM OR OTHER BODY OF WATER. A SPECIALIZED PIECE OF EQUIPMENT CALLED A DREDGE CREATES A VACUUM THAT SUCKS UP AND PUMPS OUT THE UNWANTED SEDIMENT AND DEBRIS.

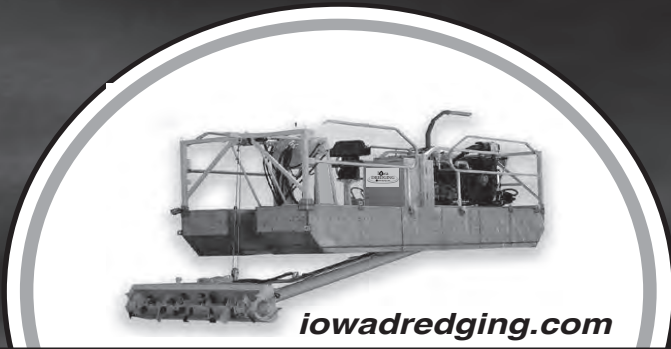

iowadredging.com

IOWA DREDGING

Doug 641-980-0828
Rusty 515-300-1290
iowadredging@gmail.com

SERVING
IA, MO, IL,
NE & KS

Iowa Dredging utilizes a compact dredge engineered specifically to facilitate removal of sediment in HOA Ponds - Sediment Basins Rural - Farm Ponds & Small Lakes.

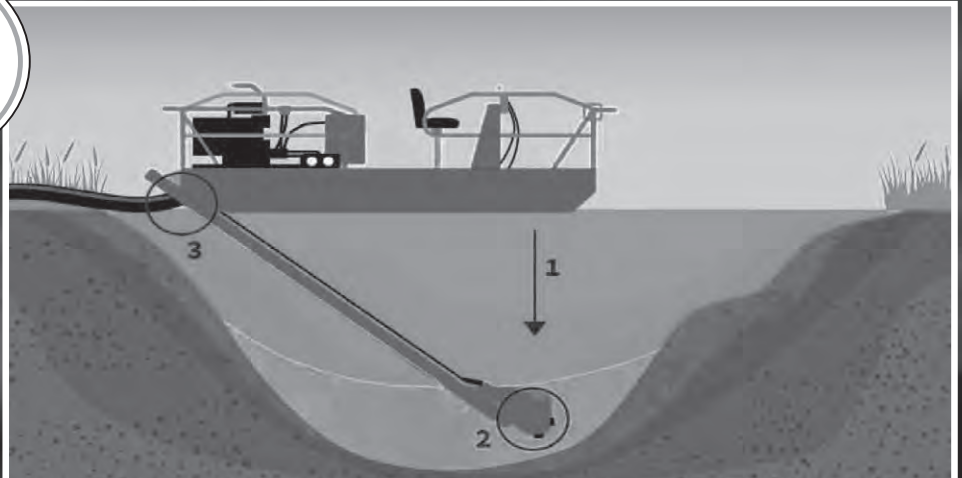

- 1** Operator lowers boom to the bottom of the body of water.
- 2** Rotating cutter-bar uses teeth to loosen settled material, as the submersible pump removes sediment from the bottom of the body of water.
- 3** the debris is transported away for final processing.

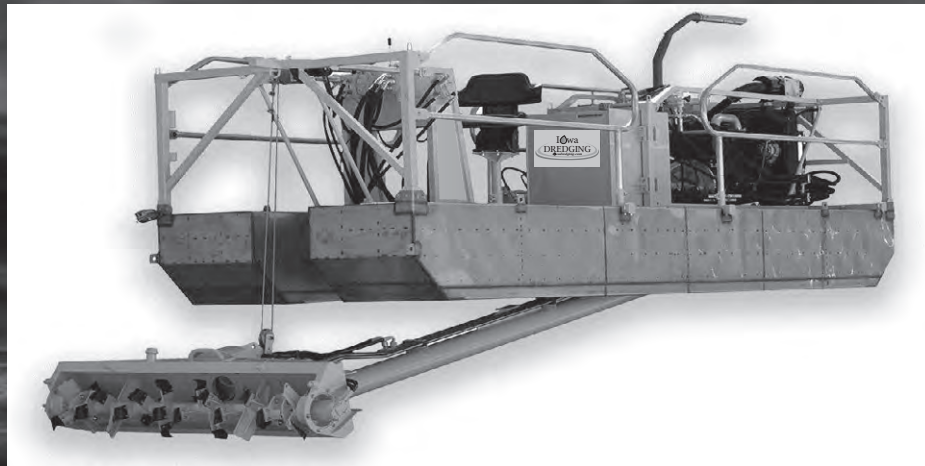

THIS PROCESS IS USED FOR

- > CREATING WATERWAYS
- > REOPENING CHANNELS
- > RESTORING SHORELINES
- > MAINTAINING ECOSYSTEMS
- > GATHERING CONST. MATERIALS
- > REMOVING TRASH & DEBRIS
- > RECONFIGURING WATERWAYS
- > INCREASING WATERWAY DEPTH
- > MINING FOR METALS
- > & MORE!

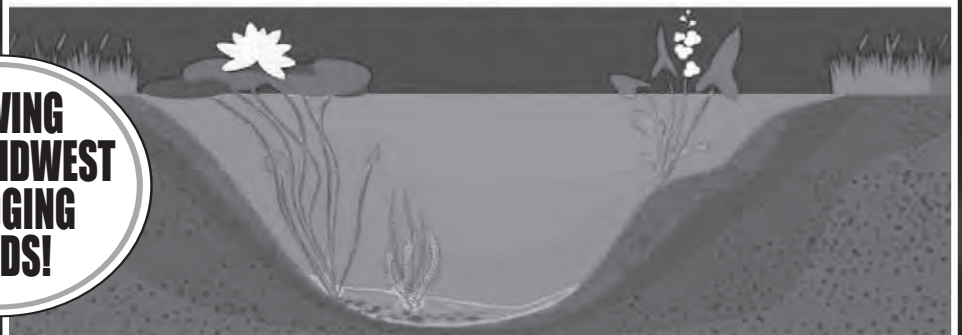

Doug 641-980-0828
Rusty 515-300-1290
iowadredging@gmail.com

**CALL US TODAY
TO GET YOUR
PROJECT SCHEDULED
FOR 2022!**

SERVING
YOUR MIDWEST
DREDGING
NEEDS!

www.iowadredging.com

Lumber - Windows - Farm Equipment
Gerald Johnson Estate
AUCTION
Saturday, Feb 19th • 9:30 a.m.
On Site - Ames, IA
Location: Interstate 35 to Exit 113 - Then 1/2 Mile East to 570th Ave
 Then 1/2 Mile North
Large Amount New Lumber - Sheeting & Windows Stored Inside Building
for Several Years!
 Check Website for Details & Pictures www.wilsonauctionservice.com
Tractors: 1968 JD 4020 Gas, Syncro, WF, 5525 Yrs on Tach w/MF 236 Hyd Loader w/6' Bucket; MF 135, WF, Gas Tractor, Motor Free, Needs Work; JD 7000 4R 30" Planter; JD Tandem Disc; AC 3 Pt 2 Btm Plow; Much More. Check Website. Scrap Buyers Be w/Us.
Terms: Cash or Good Check. Not Responsible for Theft or Accidents.
 Auction Conducted By:
WILSON AUCTION SERVICE
 Colo, IA
Bob Wilson, Auctioneer
 515-290-4789 Bob Cell

Sporting Goods Consignment Auction
Sat. February 26, 2022 • 9:00 a.m.
 2530 Hwy 22 • Riverside, IA

Guns: H&R Ruger 204 Rifle, NC Star 3-12 X50E Rangefinder Scope, Camo Synthetic Stock; Daisy Model 177 BB Gun; Buck Jones Special Winchester Model 60 .22 Cal Rifle; Taurus Model 63 .22 Cal Rifle; Like New Remington Fieldmaster Model 572 .22 Cal Rifle, Scope; Western Field model 550E 410 Pump Shotgun, 26" Barre, Full Choke, 2 3/4 & 3"; Winchester Model 1897 12 Ga, Needs Work; Remington 1148 12 Ga Shotgun, 2 3/4, Full Choke; Mossberg Western Field 12 Ga, 28" Barrel, 2 3/4 & 3"; Sears & Roebuck 550 AG 12 Ga, Vent Rib; 2 3/4 & 3", 28" Barrel; Mossberg 550 ABR, Vent Rib, 2 3/4 & 3" Chamber 12 Ga; Mossberg 550CR 20 Ga, 26" Vent Rib, 2 3/4 & 3"; Frontier .22 Cal Revolver; New White Wonder 12 Ga S.S.; Mossberg 12 Ga Pump, Scope; Knight .50 Cal Muzzleloader, Scope; Remington 1100 12 Ga Shotgun; Remington 870 20 Ga Express Shotgun; Colt Trooper .357 Cal, 4" Barrel; Browning A-5 Belgium 12 Ga Shotgun, Scope & Slug Barrel, Bird Barrel, Gold Trigger, 2 3/4 & 3"; Daisy .177 Cal Pellet Gun; Springfield M1A Scout Squad Rifle, 7.62x51/.308, Exc Cond w/Magazines; Remington Versa-Max 12 Ga Shotguns, 2.75"-3.5" 26" Vent Rib Barrel, Factory Chokes, Black Synthetic Model, Exc Cond w/NEW Versa-Max Rifled Slug Barrel.

Ammo: Lots of .22 Ammo; 30-30; .410 Super X; 410 Federal; Federal 12 Ga 4 Shot, 3 Shot; BB Steel Shot; Winchester 6 Shot; Remington 12 Ga 4 Buck; Winchester 6 Shot; Remington 12 Ga 4 Buck; Winchester AA 12 Ga 8 Shot, 7 1/2 Shot; Federal 12 Ga 7 1/2 Shot, 6 Shot; Winchester 12 Ga 2 Shot, 4 Shot; Winchester 20 Ga 6 Shot; Misc 20 Ga 4 Shot; Winchester 20 Ga 7 1/2 Shot; 3 Shot Federal; Winchester 20 Ga Shot; Winchester 20 Ga 3 Shot; Federal 20 Ga 4 Shot; Kent 12 G Steel Shot; Brenneke KO Sabot Slugs 12 Ga 2 3/4; Remington 20 Ga Slugs; Federal 20 Ga Slugs; Lots of Skeet Loads; Federal 20 Ga 7 1/2 Shot; Lots of Winchester Trap Loads; Winchester BB Steel Shot; Lots of Reloaded Shells; Winchester 12 Ga Turkey Loads; Remington 3" 12 Ga Turkey Loads; Lots of Daisy Pellets; 30-30 Rifle Shells; Lots of Other High Power Rifle Ammo; Winchester .38 Special; .22 Cal Long Rifle; Winchester .22 Short; 4 Boxes Federal Premium 12 Ga 3" Barnes HP Sabot Slugs; 26 Boxes Remington Core-Lokt Ultra 12 Ga 2.75" Sabot Slugs; 15 Boxes Remington Copper Solid 12 Ga 2.75" Sabot Slugs.

Archery: Bear Compound Bow, 33" Draw, Release, Bear Compound Bow, Arrows, Hard Case; Deer Transporting Cart; Hanging Deer Stand; Ladder Deer Stand; 20-60x60mm Spotting Scope, Tripod.

Knives: Buck 112 Folding, Sheath; Buck 118, Like New, Sheath; Buck 119, Like New, Sheath; Schrade-Walden A-15, Sheath; Western, Bone Handle; Schrade Old Timer; Soliger Cutlery, Bone Handle, German.

Fishing: Lots of Asst Fishing Rods & Reels; 5 Tackleboxes, Loaded; Lots of Fishing Lures & Supplies; Vintage Items; 10x12x3 Cast Iron Fryer; 17 Ft Grumman Canoe, Paddles; Transport Yoke, Cushions; MinnKota Fortex 101 Elec Trolling Motor.

Trapping: 140 Victor 110 Conibear; 30 220 Connibear; 25 Oneida #1 Jump; 35 Oneida #1 1/2 Jump; 40 North Woods #1 1/2 Double Coil; Double Long Spring; 12 #1 1/2 Fur Saver; #2 Double Coil; 7 #3 Double Coil; 16 #4 Double Coil; 12 #1 1/2 Long Spring Foot Traps; Cage Traps; 60 Asst Traps.

Misc Collectibles - Pictures: Turkey Posters; Hunting Signs; Lots of Framed Prints; 1989 IA Trophy Angler; 1992 Iowa Big Fish Award; Shades of September; Show Goose Decoy; Antiquity; Duck; Deer in Woods; Fishing; Black & Yellow Labs; Gun Signage; Collectibles; Vintage Items; Memorabilia; Sporting Event Items.

Reloading: Lots of Empty Ammo Shells; Pacific D-L105 Reloader; Shooters Bible Books; Dies; Lots of Misc Reloading Supplies.

Auctioneers Note: This is a Very Early Listing. Many More Items Coming in Daily. Expecting 600 Lots or More!!! This is an Auction That is Always Well Attended & Prices Are Strong. Don't Miss The Date!

Open House Friday, February 25th, 1:00-8:00 PM.
 Gun Transfers Done on Site - \$10.00 Each to New Buyer

Terms: Cash or Check w/proper ID. Not Responsible for accidents or theft. All announcements day of auction supersede previous advertising.

Auctioneers:
Delmar Yoder 319-430-2711
Lonnie Miller 319-461-0019
5starauction.com

IT'S AUCTION TIME, PEEPS!
 Every week Your Hawkeye Trader contains dozens and dozens of auctions!
 Just pick up your free copy every Friday!
 You can also see the auctions online every Thursday morning!
 Browse the auctions!
 Print the sale bills!
 We make it super easy for you to check out all the area auctions each week!

www.hawkeyetrader.com/auctions



~~\$21,975 OBO~~

\$20,975 OBO

2014 Ford Expedition EL XLT
 4x4, 5.4 V8, 3rd Row Power Seats, Heated & Cooled Front Power Seats, Leather, Trailer Tow Pkg, Very Good Condition!

641-980-0828





SULLIVAN AUCTIONEERS, LLC

A FAMILY OWNED BUSINESS SINCE 1979



MATT



MICHAEL



LUKE



JOHN



DAN



JOE



JIM



BILL

Headquartered in Hamilton, Illinois, Sullivan Auctioneers, LLC is one of the largest Real Estate and Farm Machinery Auctioneers in the nation.

For more than 40 years we have been conducting professional auctions. We connect our sellers with thousands of interested buyers around the world.

Considering an Auction?
 CALL OR EMAIL TODAY FOR A NO OBLIGATION CONSULTATION!
 Toll Free (844) 847-2161 | Sold@SullivanAuctioneers.com
 www.SullivanAuctioneers.com | Lic. #444000107

METAL ROOFING



Installing Metal Roofing On All types of Buildings

Houses & Barns
Commercial & Residential

Customer Satisfaction Is Our Goal!

WAGLER BUILDERS

CALL TODAY FOR A FREE ESTIMATE: 641-777-5000
 EMAIL: waglerbuilders@hotmail.com
 www.waglerbuilders.com

NEW MOBILE HOMES IN STOCK
 Hurry Before We Sell Out
 marktwinmobilehomes.com
573-249-3333



'08 F450
 Crew Cab, New 6.4 Twin Turbo Engine, AT, 4x4, XLT Lariat, Leather, Alloys, New Rubber, Flatbed, 250K
\$22,995

LAMBIRTH'S TRUCKS
641-943-2551

STANDING TIMBER BUYER

All Species & Select Yard Trees Over 40 Inches Diameter Certified
 Bonded w/Iowa DNR
Jaguar Lumber
 Bloomfield, IA
641-664-2080

BUY, SELL, TRADE: Gold, Silver, Jewelry, Coins, Pocket Watches, Indian Artifacts, Bullion, Black Powder, Antique Firearms, Proof Mint Sets, National Bank Notes, \$500 & \$1,000 Bills, McKee Coins
 641-684-6006 2-11

Golden Grain Bins Winter Discount

Grain Bins	Floors W/12" Supp. & Flashing
18'x18' 4,195 Bu. \$4,476	18' \$1,111 30' \$3,106
27'x21' 11,265 Bu. \$8,565	21' \$1,520 36' \$4,429
42'x24' 32,245 Bu. \$19,029	27' \$2,537 42' \$6,032

GMLS Industries, Inc.
PH: 660-699-2179
Or 888-983-2136
www.gmlsindustries.com



2006 FLHTC
 Chrome Frt. End, Spoke Wheels & Rotors, D&D Fit Cut Exh., Cam, Tuner, Custom Seat, Sissy Bar & Rack, Nice Bike!

NO DOC FEES! **\$7,995**

C&C Cycle
 Chariton, IA • 888-475-2243
www.cc-cycle.com

DO YOU NEED SOME BEES? We Are Taking Orders For Package Bees Until The End Of Feb. Open 3 Days A Week. Mon, Fri, Sat.
 Shady Lane Bee Supplies
 5485 St. Hwy M Moberly, MO 65270 2-17

FOR SALE: USED STEEL PIPE 2 Inch To 48 Inch Diameter, Located Carrollton, MO. For Details Call Redmount Midstream LLC.
 660-542-3000 2-25















NOTICE!
THE HAWKEYE TRADER reserves the right to refuse any ad or to edit any portion of an ad at any time. **The Hawkeye Trader** will give credit for only one week of incorrect ad copy. If there is an error in the first week's publication, call our office and an adjustment will be made. In case of error your ad may be run in the following week's edition at no charge or you may request a refund or credit on your bill. **The Hawkeye Trader** does not accept liability for any loss or damage caused by an error or inaccuracy in the printing of an ad beyond the amount paid for the space occupied by the advertisement in which the error occurred. **The Hawkeye Trader** cannot guarantee specific page or location placement of any ad. There will be a \$10 check return fee for any NSF check. We are not responsible for illegible copy received in mail. If your item in the paper is sold before your ad runs out or after we receive it we will issue you credit for further advertising. Any pictures for display ads received become the property of **The HawkeyeTrader** unless accompanied with a self addressed stamped envelope.



SAM'S RIVERSIDE REPAIRABLES

805 SE 30th St • Des Moines, IA • Phone 515-265-1212 • Toll Free 800-308-4096 • www.samsriverside.com

REPAIRABLES 515-265-1212 PARTS 515-265-8792 HEAVY TRUCKS 515-265-1656

 <p>SKU: E33224 2011 Jeep Liberty Limited 4x4, 3.7L, 6 Cyl, 89,015 Miles \$10,900</p>	 <p>SKU: 956631 2009 Chevrolet Avalanche 2LT 4x4, Crew Cab, 5.3L, 8 Cyl, 115,494 Miles \$14,900</p>	 <p>SKU: A20597 2010 Buick Lucerne CXL3 3.9L, 6 Cyl, 32,960 Miles \$10,900</p>	 <p>SKU: D46507 2013 GMC Yukon Denali 4x4, 3rd Row, Regular Title, 6.2L, 8 Cyl, 58,668 Miles, \$26,900</p>	 <p>SKU: D45716 2013 GMC Sierra 2500 SLT 4x4, Crew Cab, 6.0L, 8 Cyl, 63,837 Miles \$32,900</p>
 <p>SKU: E75401 2014 Chevrolet Silverado 2500HD LT 4x4, Crew Cab, 6.0L, 8 Cyl, 93,273 Miles \$24,900</p>	 <p>SKU: E81911 2014 Chevrolet Silverado 1500 LT 4x4, Crew Cab, Lifted, Fuel Wheels, 5.3L, 8 Cyl, 63,243 Miles, \$22,900</p>	 <p>SKU: F34443 2015 Ford F150 Platinum 4x4, Crew Cab, 3.5L, 6 Cyl, 92,281 Miles \$27,900</p>	 <p>SKU: G10753 2016 Chevrolet Suburban K1500 LTZ 4x4, 5.3L, 8 Cyl, 59,806 Miles \$32,900</p>	 <p>SKU: J41724 2018 Chevrolet Silverado 2500HD W/T Double Cab, 4x4, 6.0L, 8 Cyl, 74,818 Miles \$27,900</p>
 <p>SKU: K42205 2019 Ford F250 Super Duty Lariat 4x4, Crew Cab, Theft, 6.2L, 8 Cyl, 31,737 Miles \$46,900</p>	 <p>SKU: L04537 2020 Dodge Ram 2500 Tradesman 4x4, Crew Cab, 6.4L, 8 Cyl, 33,260 Miles \$39,900</p>	 <p>SKU: H84292 2017 Chevrolet Equinox LT AWD, 2.4L, 4 Cyl, 81,742 Miles \$13,900</p>	 <p>SKU: M70668 2021 Mazda CX-5 Sky Active G Touring 2.5L, 4 Cyl, 3,259 Miles \$23,900</p>	 <p>SKU: L23985 2020 Nissan Frontier SV 4x4, Crew Cab, 3.8L, 6 Cyl, 5,348 Miles \$26,900</p>

Our Hours Are 8:00 AM - 5:00 PM M-F - Sat 8:00 AM - 2:00 PM - Sun 1:00 PM - 5:00 PM

Harbison Brush Mowing
 Brush Mowing • CRP Fields • Timber • Trails
 Pasture Cleanup • Tree Shear • Fence Rows

Jeremy Harbison
 Cell: 319-461-0376
 Home: 319-694-2300

HARBISON FENCING
 "For All Your Fencing Needs"
Barbwire • Woven Wire
Silt Fence • Vinyl Fencing
Hi Tensile
 319-694-2300 - Home
 319-461-0376 - Cell

\$24,995

'11 Ram 3500
 Crew Cab, Short Box,
 Cummins, Auto, 4x4,
 Deleted Big Bumper,
 Both Hitches, New Tires,
 Leveling Kit, 225K
 Just In!!

LAMBIRTH'S TRUCKS
641-943-2551

2017 Polaris Ranger XP 1000
 4x4, 5K Miles,
 Solid Machine

NO DOC FEES! **\$12,995**

C&C Cycle
 Chariton, IA • 888-475-2243
www.cc-cycle.com

TIMBER MANAGEMENT:
 Buying Standing Timber.
 Bonded & Insured.
 PAID IN FULL PRIOR
 to HARVESTING.
 Specializing In
 Walnut - Oak - Maple, Cole.
 641-895-8209 12-31-22

MCKEE COINS INC: 213
 East Main Street, Ottumwa,
 IA 52501. <http://mckeecoins.com>.
 Specializing in Coin
 Auctions, Gold, Silver &
 Bullion.
 641-684-6006 2-11

PETE'S TIRE & AUTO REPAIR



301 N. 2nd Pulaski, IA
 All Major Brands:
 Car, Light Trucks & Farm Tires,
 Auto Service & Mechanical
 Mon.-Fri. 8-5
641-675-3650 Sat. 8-12



STOCK MOBILE HOMES AVAILABLE
 We Gottem, Single And Double,
 3 And 4 Bedroom!
 Call Tuffy • 573-657-2176
www.amegamobilehomes.com



Are you tired of your current job?
 Do you enjoy driving and seeing different scenery?
 We have the perfect job waiting for you.

Shiloh Express LLC, of Mt Pleasant, IA., is currently searching for owner operators who have their own 1 ton or 3/4 ton pickups and a 30 to 35 foot flatbed gooseneck trailers. We have a lot of in house freight that has the potential of delivering across the United States so that you can see different parts of the country and make good money too. You will sign on under our Authority and DOT number as an Independent Contractor and depending what the GVWR combination weight of your truck and trailer, you may not even need a commercial CDL to hire on. We get you set up with commercial Insurance, provide you with signage for your truck and you are ready to start your new adventure. Average weekly pay is \$2000 to \$2500. If this sounds like something you would be interested in, please give us a call and we will go over all of the details for your new exciting career.

Shiloh Express LLC - Mt Pleasant, IA
319-385-1989

I am Looking to Buy Your Deer Antlers, Sheds & Heads



Big & Small, I Buy Them All!!!
Ronnie Coffelt
417-339-1462

CLASSIFIED COUPON
 Use the Power of Your Traders for Regional Classified Results!
 Clip this coupon to run a Classified Ad for **\$8.75** for one week.
 1 Classified Ad for two weeks or 2 Classified Ads for one week for **\$17.00**.
Picture ads are not included with coupon, call for pricing.
 Each ad must be 20 words or less. additional 20¢ per word over 20 words

AD NO. 1: (20 Words Or Less)

AD NO. 2: (20 Words Or Less)

Triple Your Classified Ad's Power By Running It In The Traders
The HAWKEYE TRADER, SHOW ME TRADER & MID-MO TRADER!
 WHEN YOU SELECT ALL THREE TRADERS, YOUR AD WILL BE READ IN OVER 170 COUNTIES IN 5 STATES & ONLINE!

HAWKEYE TRADER ONLY: 1 Ad For One Week **\$8.75** (84 Counties)
 HAWKEYE TRADER ONLY: 1 Ad For Two Weeks **\$17.00** Or 2 Ads For One Week **\$17.00** (84 Counties)
 BOTH HAWKEYE & SHOW ME TRADER: 1 Ad For One Week **\$17.00** or 2 Ads For One Week **\$32.00** (150 Counties)
 BOTH HAWKEYE & MID MO TRADER: 1 Ad For One Week **\$17.00** or 2 Ads For One Week **\$32.00** (106 Counties)
 BEST VALUE: HAWKEYE, SHOW ME & MID MO TRADER: 1 Ad For One Week **\$25.00** (170 Counties)
 BEST VALUE: HAWKEYE, SHOW ME & MID MO TRADER: 2 Ads For One Week **\$47.00** (170 Counties)

To Receive This Rate, Coupon Must Be Mailed In With your Payment
 Or Use Our Website @ www.hawkeyetrader.com For More Savings Options
HAWKEYE TRADER, P.O. Box 96
Pulaski, IA 52584

2017 SUZUKI KING QUAD 400
 4x4, Foot Shift,
 Low Miles,
 Great Condition!

NO DOC FEES! **\$5,795**

C&C Cycle
 Chariton, IA • 888-475-2243
www.cc-cycle.com

LAN-DOW BUILDINGS
 "We Build to Suit Your Needs"
 "Custom Built"
 Pole Barns
 Garages
 Utility Buildings



"H" Don or Dick Middleton
Memphis Lumber Co.
1-800-337-5858
Phone: 660-465-8595
Fax: 660-465-8596

Where Quality Comes First

Are You Thinking About A Building? Bring Your Size And We'll Give You A FREE Price Quote!
WE WILL ENGINEER YOUR TRUSSES TO YOUR SPECS

BUILDING PACKAGES (TAXES INCLUDED)
SERVING THE TRI-STATE AREA SINCE 1992

Call For Pricing On Building Packages!

- WE WILL DELIVER -
FREE ESTIMATES ON ALL BUILDINGS
 WE MANUFACTURE STEEL ROOFING,
 SIDING AND TRIM, CUT TO THE INCH.

BUY DIRECT AND SAVE!

BUILD IT YOURSELF OR HAVE ONE OF OUR PROFESSIONAL CONTRACTORS DO IT FOR YOU.

We Work Hard For Your Success. Your Business & Satisfaction Is Important To Us!

4 MILES SE OF REVERE, MO
OR 6 MILES NW OF WAYLAND ON C.
26758 HWY C., ALEXANDRIA, MO 63430

WAGLER METALS Missouri Warehouse
 MON.-FRI. 7AM-5PM
 SAT. 7AM-2PM

HEAT WITH THE MOST TRUSTED OUTDOOR WOOD BOILER ON THE MARKET



THE PRISTINE SERIES NOW QUALIFIES FOR A 26% FEDERAL TAX CREDIT.
STAINLESS STEEL
EASY MAINTAINENCE
20 YEAR LIMITED WARRANTY
LARGE INVENTORY IN STOCK OF DIFFERENT MODELS
EXPERIENCED INSTALLING DEALER
Chris Lee Winterset Iowa
CROWNROYALSTOVES.COM (515) 208-3903

- Want To Buy -
 Large Quantities Of Dimes, Quarters, Halves & Silver Dollars Dated Before 1964
 Pay Top Cash For Large Coins & Currency Collections
 Buying \$500 & \$1,000 Bills
 Rolex Watches & Pocket Watch Collections
 Pay Cash On The Spot
 Will Travel Anywhere to Buy
 Try Us - You Will Be Pleased
Wallis Company - Max Hagen
 Cedar Rapids, IA • Same Address For 50 Years
 Call For Info:
319-396-7760 Or 319-360-0213

VIRTUAL LIVE ONLINE
MARION COUNTY, MISSOURI
LAND AUCTION
 THURSDAY, MARCH 10, 2022 AT 10:00 A.M. CST

343± ACRES
 (Subject to survey)
5 Tracts

VIRTUAL AERIAL VIDEO ONLINE!

✓ **HIGHLY PRODUCTIVE TILLABLE CROPLAND!**
 ✓ **UNPRECEDENTED DEVELOPMENT OPPORTUNITY!**
 ✓ **PRIME RURAL BUILDING SITES!**

Land is located 13 miles west of Quincy, IL or 12 miles northwest of Palmyra, MO in Sections 1, 12, 27 & 28, T59N•7W and Section 7, T59N•R6W, Fabius Township, Marion County, MO.

THE DONALD E. REDD TRUST
 REPRESENTING ATTORNEY: JOHN BRISCOE | BRISCOE & BRANNON
 423 SOUTH MAIN STREET | NEW LONDON, MO 63459 | (573) 985-3411

TITLE WORK: ACCURATE LAND TITLE CO.
 218 BROADWAY | HANNIBAL, MO 63401 | (573) 221-1002

AUCTION MANAGERS:
 BILL FRETWELL (660) 341-7735 & JENNIFER WOOD (217) 257-8812

SULLIVAN AUCTIONEERS, LLC • TOLL FREE (844) 847-2161
 www.SullivanAuctioneers.com • IL Lic. #444000107

TINY HOMES
 WE GOT TOM
573-881-3283

LOOKING TO LIQUIDATE OR DID YOU JUST INHERIT STUFF: Let Me Help. On-Site Tag Sale Services. Personal Property And Collectible Consultation. Also Seeking Baseball Cards, Furniture, Comic Books, The Unusual, And Anything Of Value. Before Throwing Out Your Potentially Valuable Items, Contact Me. CAGA Certified. Nathan Lilley. 573-253-4159 TFN

FOR SALE: Hundreds of Live Edge Slabs in Stock. Specializing in 40 Inches Plus Diameter Slabs/Logs. Jaguar Lumber 641-664-2080 TFN

FREE HEAT & HOT WATER: Eliminate Monthly Heating Bills w/Classic Outdoor Wood Furnace. No Sunday Calls. 660-707-3866 TFN



Looking for a New Ranger?
 Call Today to Get Priority Placement on a New Ranger!

NO DOC FEES!
C&C Cycle
 Chariton, IA • 888-475-2243
www.cc-cycle.com

SCOTT HUSKEY'S HOME SERVICE!!: Insulated Skirting for Manufactured or Older Site Built Homes. Eliminates Frozen Water Lines & Cold Floors. Save 20 to 25% on Utility Costs. I Also Have an Uninsulated Heavy Duty Vinyl Skirting-Looks Great! Since 1972 573-696-3468 TFN

PETS
 FOR SALE: Shiba Inu Puppies, APR Registered, Shots, 1 Male, 1 Female, \$150, Born 6-24-21. 641-895-5112 2-11

GREAT PYRENEES: Puppies Ready February 3rd., Parents Guard My Sheep With Zero Predator Issues. Price \$250.00 Firm. 7 Available. 660-988-0569 2-11

FOR SALE: Terrier Puppies, Wormed, First Shots And Vet Checked. 660-956-2961 2-11

PUPPIES, PUPPIES: We Want to Buy Your Puppies! Registered or Mixed Breeds. We Have Homes Waiting for Them! 573-784-9866 TFN

REAL ESTATE
HOMES!: 16X80 New Single Wide, 3 Bdr - 2 Bath, \$72,500.
Lincoln Homes
 Hwy 30
 Ogdan, IA 50212
 lincolnhomesia.com
 515-275-2717 TFN



\$14,000
New 2022 16' Iron Star Dump Trailer
 Bumper Hitch, Tarps, Ramps
LAMBIRTH'S TRUCKS
641-943-2551

AG RELATED
 FOR SALE: 2012 JD 1990 CS Air Drill, 35 Ft., 15 Inch Spacing, Low Acres, Purchased New. 641-208-0424 2-25

FOR SALE: 24 Ft x 5 Ft Free-Standing Cattle Panels, Weighing 600 Lbs Each, Fastener Chains Included. Located in Troy, IA. 641-680-0892 TFN

MASTER BUILDERS
Post Frame Buildings



24 x 30 x 10 1-10x8 Overhead Door
Concrete Floors \$25,200

30 x 40 x 10 1-10x8 Overhead Door
Concrete Floors \$30,000

All Sizes On Sale
 Price Includes All Tax and Labor
Call (641)295-4970 • (641)295-4467
 Customers are responsible for all permits.

Save Some Trees!
Read The Paper Online!
www.hawkeyetrader.com

ANTIQUES & COLLECTIBLES AUCTION
SATURDAY, FEBRUARY 19TH, 2022, AT 11:00 A.M.
FAIRGROUNDS COMMUNITY BUILDING • WINTERSSET, IOWA

SNOW DATE: SUNDAY, FEB. 20TH @ 12:00 NOON

ANTIQUES & COLLECTIBLES: Chicken collection; Fenton items; Other good glass items; Hair picture; Budweiser mirror; Old toy Ford backhoe; Toy trucks & cars; Stoneware jugs & bowls; Hanging lamp; Enamel canteen; '60's radios; Marbles; Dozens of Comic, Superman & others; Beater jars; Bird feeder; Easel; Bird planters; John Deere books; Stove finial; Juice set; Cherry pitter; Lightning rods; Cistern pump; Advertising clock; New spark plugs; 12" anvil; Prints; Some tools; Wood boxes; Leather umbrella stand; "Gone With the Wind" lamp; Air compressor; Red Wing Sanitary water bowl; RP Co. Ltd. Rochester PA. 6 gal Salt glazed crock; 6 Gal hand-turned unmarked crock; Red Wing 3 gal Birch leaf crock; Minnesota Stoneware 1 gal jug w/paper label; Minnesota Stoneware 1 gal bottom-marked crock; Blue & white Logan Pottery foot warmer; Minnesota Stoneware 10 gal salt-glazed Single leaf crock, front stamped, damaged; Blue & White grapes stoneware pitcher; Brown & green spatterware pitcher; T&T Johnson & Son Grand River, IA Stoneware rolling pin; Falstaff lighted clock, all orig, works; Falstaff clicking mugs lighted sign, new cond, works; Michelob Dry lighted sign, all orig, works; Budweiser Pheasant bubble lighted sign, orig, works; Budweiser trout bubble lighted sign, works, redone inside; Silver Mountain toy train; Battery operated toy drum, needs work; Roy Rogers & Dale Evans thermos; Disney's Wonderful World lunch box & thermos; Disney's Magic Kingdom lunch box & thermos; Disney's The Fox & Hound Lunch box & thermos; Batman thermos & book; Disney's Mickey Mouse lunch box & thermos; Large lighted globe; Rubber Birds night light, rewired; A few Tobacco tins; and more.

ARTIFACTS FROM MISSOURI & IOWA: 14 Ax heads; 7 Silks; Spear point; Fishhook; 87 Points, Bird & other regular points.

TERMS OF SALE: ID is required to receive bid numbers. We accept cash & checks, no cards. We are not responsible in case of accident or theft. **LUNCH SERVED**



HARTMAN AUCTIONEERING
 Steve Hartman - Cell 515-468-7857, Home 515-462-4584
www.hartmanauctioneering.com

HINSHAW TRAILER SALES
RICHLAND, IA 52585

319-456-6611
 701 Highway 78 East
 Richland, Iowa

2015 PJ 40' GN/FB
 w/NEW Elec/Hydraulic Disc
 10K Brakes,
 Toolbox Storage,
 Fold Over Jacks
\$15,200

NEW Maxwell GN/Dump 83"x16'
 Garbage Tarp,
 Toolbox,
 14,000 GVW,
 Remote & Ramps
\$15,500

NEW Maxwell Bumper Dump 83"x14'
 Garbage Tarp, Toolbox,
 14,000 GVW, Remote & Ramps
\$12,500

NEW Maxwell Bumper Dump 5'x10'
 Garbage Tarp,
 Toolbox, 7,000 GVW,
 Remote & Ramps
\$9,500

For our full inventory, Visit Us At
www.hinshawtrailersales.com

15 ~~20~~ ~~21~~ ~~23~~ ~~45~~ Trikes In Stock
Ready To Go and Building More
 We Install Trike Kits on Hondas, Yamahas, Harleys, Triumphs, Victories, Suzukis & Kawasakis! Get Your Trike Kits Ordered Today! 4 Weeks For Delivery! We Do Hannigan, California Side Car, FBI, Champion, Lehman, Frankenstein, Mystery Design, Motor Trike Kits!
 We Also Carry Can Am Spyders.
 888-475-2243 • Chariton, IA
www.cc-cycle.com - Click on Trike Gallery!
Prices Starting @ \$9,995 For Complete Units!
Kit Prices Starting @ \$5,295
 We, Also, Carry, Vanderhalls.
2020 Vanderhall Carmel & Venices In Stock!

 We Can Finance Kits! Zero Down Financing With Interest As Low As 4.59% WAC
C & C CUSTOM CYCLE
888-475-2243

Slayton
POLARIS
10456 State Route B, Downing, MO 63536
slaytonpolaris.com
660-328-6627
 2022 POLARIS RANGER 1000
 CALL DEAN OR TIM FOR SPECIAL PRICING!

SOUTHEAST IOWA STEPS

More Sizes Available
For Sales & Service Please Call Chris At 641-919-6922
Check Us Out On Facebook
Steps • Stock & Custom Railings



\$12,900

2008 Chevrolet Suburban
 3/4 Ton, 4x4, 6.0 Engine, 9 Passenger, 249,000 Miles
660-341-3040

2017 FLHX Street Glide
 Screaming Eagle Mufflers & Air Cleaner, 39K
NO DOC FEES!
\$18,995
 C&C Cycle
 Chariton, IA • 888-475-2243
www.cc-cycle.com

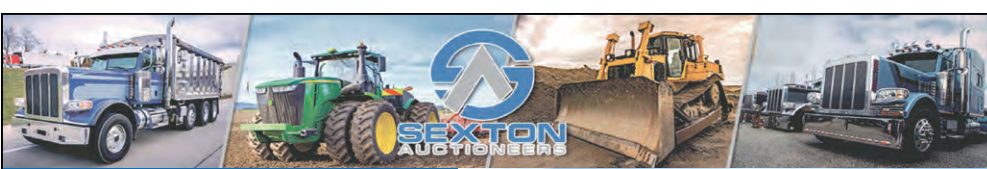

ONLINE ONLY EQUIPMENT AUCTION
 Internet Bidding closes at 11:00 am CST
THURSDAY, FEB. 24, 2022
www.SextonAuctioneers.com
BID NOW!
Much more equipment online!

 2015 International Prostar	 2014 Peterbilt 579	 1995 Ford LA9000	 2020 Kenworth W900L	 2009 Caterpillar 963D
 2007 Wilson Hopper / Grain Trailer DWH-551	 1983 Nutall 225E fixed neck lowboy	 1987 Frameless End Dump With Homemade title	 2003 Kenworth W900 Dump Truck	 2003 Kenworth W900 Dump Truck
 2005 Peterbilt 357 Dump Truck	 2007 Mack CV713 Dump Truck	 2000 Kenworth T800 Dump Truck	 2000 Western Star 49645X Dump Truck	 2012 John Deere 35D
 2012 John Deere 6115D	 Kubota B2601 HSD tractor Backhoe loader	 JLG SkyTrak 10054 Telehandler	 2007 Genie TGH 1056 Telehandler	 Wiggins Yardbull WD256 Forklift truck
 2020 Case TR310B	 2018 Case TV380	 2017 John Deere 331G	 2019 Bobcat T595	 2018 Bobcat T770
 2019 Grand Design Reflection Camper Trailer	 2012 Ford F-250	 1998 Dodge Ram Pickup Truck	 2010 Chevrolet Tahoe	 2005 Ford F-550
			 150+ Skid Steer Attachments	

FOR SALE: 1st And 2nd Cutting Of Alfalfa And Grass Mix Round Bales, Net Wrapped, No Rain, \$70. 515-669-0704 2-18

FOR SALE: Big Round Bales Dry Hay Wrapped In Plastic, No Rain, First And Second Cutting, Alfalfa/Clover/Grass Mix, 200 Bales, \$35-\$70 A Bale. 641-722-3002 2-11



FOR SALE: 100 Orchard Grass, 50 Brome, 40 Alfalfa, 100 Straw In Big Square Bales. Also 200 Straw In Big Round Bales. All In Barn Near Cairo, MO. Please Call For Price. 573-470-0077 2-11

\$27,995
'16 Chevy Silverado 1500
 LT, Crew Cab, 5.3, AT, 4x4, 110K, Alloys, Tow Pkg., Bed Cover, Steps, Tow Mirrors, Camera
LAMBIRTH'S TRUCKS
641-943-2551

AUTOMOTIVE
FOR SALE: 2011 Ram 1500 Big Horn, 4x4, Quad Cab, 5.7 V8, Auto Full Power Tow, Sharp, 132K, \$19,000. 641-820-0348 2-18

FOR SALE: 1994 Jaguar Vanden Plas XJ6, Maroon, 6 Cyl Auto, Leather, Moonroof, 54K Miles, \$3,000. 641-203-9299 TFN

FOR SALE: 4 BFGoodrich Tires LT285/60R18, 5/32 Tread, \$25 Each, Call. 319-931-3838 2-18

ATTN TRUCK OWNERS: Rhino Linings Offers You The Worlds Number One Sprayed In Truck Bedliner. Also Works On Livestock Tanks, Creep Feeders, Horse Trailers, Etc. Call For An Appointment & More Info. 641-799-5672 TFN

VIRTUAL LIVE ONLINE
ADAIR COUNTY, MISSOURI
LAND AUCTION
TUESDAY, MARCH 1, 2022 AT 1:00 P.M.
80± ACRES (SUBJECT TO SURVEY) 1 Tract
 Land is located approximately 6.5 miles north of Novinger, MO or approximately 15 miles northwest of Kirksville, MO in Sections 3 & 10, T63N•R17W, Morrow Township, Adair County, MO.
LAND REPRESENTS NEARLY 100% HIGHLY PRODUCTIVE TILLABLE CROPLAND WITH HWY. 0 FRONTAGE!
GORDON FARMS
 REPRESENTING ATTORNEY: Wallace W. Trosen LLC
 1 Crown Drive #102 | Kirksville, MO 63501 | (660) 665-4070
 TITLE WORK: Pickell Abstract Co.
 115 S. Franklin Street | Kirksville, MO 63501 | (660) 665-8324
AUCTION MANAGERS:
 BILL FRETWELL (660) 341-7735 & JENNIFER WOOD (217) 257-8812
SULLIVAN AUCTIONEERS, LLC • TOLL FREE (844) 847-2161
www.SullivanAuctioneers.com • IL Lic. #444000107

CALL TYLER SEXTON TO SELL YOUR EQUIPMENT!
www.SextonAuctioneers.com
 For any questions call our Office: 314-529-0124
 Auction Contacts Tyler Sexton | Gary Sexton
 5182 US Hwy. 63 • Pomona, MO • email: Sales@SextonAuctioneers.com
Next Auction
APRIL 28



**68054 US HWY 30
COLO, IOWA • 1-641-377-2244**

**CHECK OUT OUR INVENTORY ONLINE
WWW.TWINANCHORSRV.COM**

Colo, IA

**SELL US YOUR
TRAVEL TRAILER!**

"No Hassle, Cash Offer"

Post & Pole Frame Buildings



Specializing in:
Post Frame Buildings
(Up to 100' Wide Clear Span)
Agricultural • Commercial
Residential • Equine
Heat Formed Metal Roofing & Siding
With 50 Year Warranty

**Quality Workmanship
Best Quality Material**





**2 Miles N. of Drakesville on pavement
888-371-4710 • 641-722-3505
17549 Husky Trail Drakesville, IA 52552**

LIVESTOCK

FOR SALE: 21 Outstanding Simmental And Sim-Angus Cows. Bred To Top Bulls Of The Breed To Start Calving 2-15-22. Average Age Coming 6 Yrs. Preg-Checked In 3rd Stage. Average 1400 lbs. Papers Available. Drake Simmental. Centerville, Iowa. 641-895-9422 2-11

BULLS FOR LEASE: Over 70 Registered Angus & Hereford To Choose From. 90 Day Lease \$900. Trucking Available At Extra Charge. Kingdom City, MO. 573-999-3197 TFN



CRP SEED:

March 11th Is The Deadline To Sign Up For NEXT YEAR'S General CRP Program.

Today Is A Good Day To Order Your Seed Needs For THIS YEAR'S CRP.



**Office: 641-766-6790
800-582-2788 Or 800-Lucas88
Cell: 641-340-0294
john@prairieseedfarms.com**

FOR SALE: Quality Holstein Angus Cross Feeder Calves On Kalmbach Feed, Complete Vaccination Program, Trailer Size Loads, For More Info Or Pictures. 814-229-2401 2-25



2012 Heritage Softail
Windshield, Sissy Bar & Luggage Rack, Passenger Floor Boards, 18K

NO DOC FEES! **\$12,995**

**C&C Cycle
Chariton, IA • 888-475-2243
www.cc-cycle.com**

MISC

BUILDING MATERIALS FOR SALE: 2X4'S, Half Inch Plywood And OSB. 515-290-2901 2-25

FOR SALE: Used (47) 50 Ft. Trusses; 120 Sheets Of 27 Ft. Long Steel Siding/Roofing Panels; 140 Sheets 20 Ft. Long X 3 Ft. Wide Corrugated Plastic Ceiling Panels; (200) 20 Ft. 2x4's. Best Offer. 641-660-6838 2-18

**Save Some Trees!
Read The Paper Online!
www.hawkeyetrader.com**

February

CCW GUARDIAN

WATCH THE TOUR & DOWNLOAD THE **FREE APP:** **ccwguardian.com**



SURVIVING A DEADLY ATTACK IS ONLY THE FIRST STEP. NEXT YOU MUST SURVIVE THE LEGAL AFTERMATH.



CCW GUARDIAN HELPS PROTECT YOU FROM UNWARRANTED CRIMINAL PROSECUTION AND CIVIL LITIGATION AFTER AN INCIDENT. IN FAR TOO MANY CASES A LAWFUL CITIZEN IS UNJUSTLY MADE OUT TO BE THE AGGRESSOR. YOU STAND TO LOSE YOUR FREEDOM AND ALL YOU HAVE WORKED FOR. BY ACTING RESPONSIBLY AND ACCURATELY DOCUMENTING YOUR TRAINING WITH CCW GUARDIAN YOU BUILD A SHIELD TO PROTECT YOURSELF AGAINST ALLEGATIONS OF CRIMINAL OR CIVIL MISCONDUCT.

TRAIN. SHOOT. LOG. DETAILS MATTER.

TIMED ONLINE • NO-RESERVE
ESTATE AUCTION
 BIDDING CLOSES: TUESDAY, MARCH 8TH STARTING AT 10:00 A.M.
 PHYSICAL ADDRESS: 17665 DEXTER RD., LINNEUS, MISSOURI
 EQUIPMENT INSPECTION: SATURDAY, FEBRUARY 26TH • 9:00 A.M. - 4:00 P.M.



WESLEY GROVES ESTATE
 EQUIPMENT QUESTIONS:
 SETH LINK (660) 247-3659
 AUCTION MANAGERS:
 CODY HOLST (217) 242-8747
 MATT SULLIVAN (309) 221-7001

Highlights Include: 2003 John Deere 7220 2wd tractor, 2,545 hours; 1992 John Deere 4560 2wd tractor, 4,742 hours; 1985 John Deere 4450 2wd tractor, 5,967 hours; 1989 John Deere 9500 4wd combine, 3,865 eng./2,689 sep. hours; 2002 John Deere 920F 20' platform; 1998 John Deere 693 6 row 30" corn head; Killbros 20' head cart; E-Z Trail 21' head cart; 1998 John Deere 1780 6/11 planter; John Deere 8000 12' drill; 2002 Chevrolet C8500 grain truck, 195,775 miles; 2007 TravAlong 20' steel livestock trailer; 2005 Doolittle Xtreme 18' x 7' flatbed trailer; Shop built 24'x8' flatbed trailer; Shop built 20' flatbed trailer; Shop built 7'x4.5' flatbed trailer; 2003 John Deere 980 26' field cultivator; 2004 John Deere 637 22' disk; Case-IH 3900 18' disk; John Deere Er014 6 row 30" cultivator; John Deere 2-pt. 4-bottom plow; John Deere 915 7 shank V-ripper; EZ-Trail 510 grain cart; Westfield MK80-61 8"x61' swing away auger; Killbros 100 bu. gravity wagon; John Deere 1219 9' mower conditioner; John Deere 346 small square baler; John Deere 680 5-bar rake; John Deere 350 9' sickle bar mower; Bush Hog 2815 15' batwing mower; Bush Hog 160-10 10' 3-pt. blade; John Deere 350 manure spreader; Gehl 125 mix-all grinder mixer; John Deere 210 feed wagon; Kewanee 3-pt. 8' blade; Toyota 3FGL20 forklift; 2002 Honda TRX350 Rancher 4wd ATV; Danuser F8 3-pt. post hole digger; John Deere bale spear; 36" pallet forks; 12' telescopic boom; 20 gal. ATV sprayer and other farm support items

(844) 847-2161 | sold@sullivanauctioneers.com | www.SullivanAuctioneers.com | Lic. #444000107

GREAT SELECTION OF YOUTH QUADS ARE IN!



NO DOC FEES! **NOW IN!**

C&C Cycle
 Chariton, IA • 888-475-2243
 www.cc-cycle.com

WANTED
Standing Timber
 Buying Walnut, Oak and Maple
 20 Years In The Business
 I Pay Before I Cut
RJ Lumber LLC • Raymond Yutz
 VM: 641-722-3348



SCOTT HUSKEY'S HOME SERVICE!!! Insulated Skirting for Manufactured or Older Site Built Homes. Eliminates Frozen Water Lines & Cold Floors. Save 20 to 25% on Utility Costs. I Also Have an Uninsulated Heavy Duty Vinyl Skirting-Looks Great! Since 1972
 573-696-3468 TFN

BUY, SELL, TRADE: Gold, Silver, Jewelry, Coins, Pocket Watches, Indian Artifacts, Bullion, Black Powder, Antique Firearms, Proof Mint Sets, National Bank Notes, \$500 & \$1,000 Bills. McKee Coins
 641-684-6006 2-11

DO YOU NEED SOME BEES?! We Are Taking Orders For Package Bees Until The End Of Feb. Open 3 Days A Week. Mon, Fri, Sat.
 Shady Lane Bee Supplies
 5485 St. Hwy M
 Moberly, MO 65270 2-17



Iron Star Flatbeds
 Just In



Call for Pricing

LAMBIRTH'S TRUCKS
 641-943-2551

Valentine's Day

Multiton EME30 Electric Pallet Truck
 30" Forks, Works Well in Tight Places Like Cargo Trailers & Truck Boxes, Needs Battery



\$1,500 080

641-980-0828

2017 Road King
 107 Cu. In., Bags, Only 9,000 Miles



NO DOC FEES! **\$17,995**

C&C Cycle
 Chariton, IA • 888-475-2243
 www.cc-cycle.com

VIRTUAL LIVE ONLINE
SULLIVAN COUNTY, MISSOURI
LAND AUCTION
 MONDAY, MARCH 7, 2022 AT 1:00 P.M.

520± ACRES (SUBJECT TO SURVEY)
 6 Tracts



Land is located approximately 1 mile north of Winigan, MO or approximately 15 miles south of Green City, MO, along Hwy. 129 in Sections 4, 21, 22, 27 & 28, T61N•R18W, Morris Township, Sullivan County, MO.

Land represents well-maintained highly productive tillable cropland currently in improved pastureland & hay production! Farm is improved with nice country home as well as several barns, outbuildings & watershed lake.

ALLEN & TRENA JACOBS

TITLE WORK: SULLIVAN COUNTY TITLE, LLC
 102 N. MAIN STREET | MILAN, MO 63556 | (660) 265-3744

AUCTION MANAGERS:
 BILL FRETWELL (660) 341-7735 & JENNIFER WOOD (217) 257-8812

SULLIVAN AUCTIONEERS, LLC • TOLL FREE (844) 847-2161
 www.SullivanAuctioneers.com • IL Lic. #444000107

CUSTOM LOG SLABBING SERVICES: No Log is Too Big! Maximum Log Capacity 90 Inches Diameter by 27 Foot Long. Jaguar Lumber
 641-664-2080 TFN

INSTALLING: Metal And Shingle Roof. Serving The Tri-State Area, Call For Free Quote.
 660-730-0233 2-18

MCKEE COINS INC: 213 East Main Street, Ottumwa, IA 52501. http://mckeecoins.com. Specializing in Coin Auctions, Gold, Silver & Bullion.
 641-684-6006 2-11

FOR SALE: USED STEEL PIPE 2 Inch To 48 Inch Diameter, Located Carrollton, MO. For Details Call Redmount Midstream LLC.
 660-542-3000 2-25

FOR SALE: Hundreds of Live Edge Slabs in Stock. Specializing in 40 Inches Plus Diameter Slabs/Logs. Jaguar Lumber
 641-664-2080 TFN

LOOKING TO LIQUIDATE OR DID YOU JUST INHERIT STUFF: Let Me Help. On-Site Tag Sale Services. Personal Property And Collectible Consultation. Also Seeking Baseball Cards, Furniture, Comic Books, The Unusual, And Anything Of Value. Before Throwing Out Your Potentially Valuable Items, Contact Me. CAGA Certified. Nathan Lilley.
 573-253-4159 TFN

TIMBER MANAGEMENT: Buying Standing Timber. Bonded & Insured. PAID IN FULL PRIOR to HARVESTING. Specializing In Walnut - Oak - Maple. Cole.
 641-895-8209 12-31-22

FREE HEAT & HOT WATER: Eliminate Monthly Heating Bills w/Classic Outdoor Wood Furnace. No Sunday Calls.
 660-707-3866 TFN

VIRTUAL LIVE ONLINE
MARION COUNTY, MISSOURI
LAND AUCTION
88.3± ACRES • 3 TRACTS (Subject to Survey)
 MONDAY, MARCH 7, 2022 AT 10:00 A.M.



OPEN HOUSE: 7681 Hwy. MM • Hannibal, MO 63401
 Saturday, February 19th • 10 AM - 12 PM

Farm is located approximately 2 miles west of Hannibal, MO city limits in Sections 31 & 32, T57N•5W, Miller Township, Marion County, MO.

Farm represents productive tillable cropland, prime building sites with Hwy. MM frontage, recreational acreage & is improved with a well-located country home, stocked lake, historic barn, other outbuildings, all just minutes from Hannibal, MO!

CHARLES RUTTER
REPRESENTING ATTORNEY: John W. Russell
 201 W Summer Street | PO Box 161 | Monroe City, MO 63456 | (573) 735-1313

TITLE WORK: Accurate Land Title Co.
 218 Broadway | Hannibal, MO 63401 | (573) 221-1002

AUCTION MANAGERS: BILL FRETWELL (660) 341-7735
 JENNIFER WOOD (217) 257-8812 • DALE JONES (309) 299-6400

SULLIVAN AUCTIONEERS, LLC • TOLL FREE (844) 847-2161
 www.SullivanAuctioneers.com • IL Lic. #444000107

Absolute Land Auction
 Featuring 87 Acres +/- of Highly Productive Nodaway County Farmland - 90% Tillable
Thursday, March 10 - 10:05 am
 Younger Auction Gallery, 312 E. South Hills Drive, Maryville, MO



Property located just minutes from Maryville. Take Rt. V West from Younger Auction Gallery 1 mile to Icon Rd., then South 1 mile on gravel to Holiday Trail, then West 2/10th mile. Farm lies on North side of road.

Farm Features 87 Acres +/- with 80 Tillable Acres according to FSA records. Farm was in bean production during the 2021 season. Farm has been tilled and terraced with some remaining to be done if so desired. There are some border fences on three corners of farm which are in good to fair condition. There is one pond, fenced, with bass and catfish for the grandkids. This farm is gently rolling land with an excellent location for a new home site or development potential with long-range country views. **TAXES:** \$289.31

NOTE: Farm has had Triticale applied as a cover crop for new owner(s). Immediate possession for spring planting will be given at time of 10% down payment and signing of contract.

SOIL TYPES: Lamoni Clay Loam, 5 to 9% slope; Sharpsburg Silty Clay Loam, 2-5% slope; and Lamoni Clay Loam, 9 to 14% slope (only.3 acres).

AUCTIONEER'S NOTE: If looking to expand your farming operation or to broaden your portfolio with many opportunities whether development or new home site with income, this is it. This farm will never come up for sale in our lifetime again. Make financial arrangements now, for this farm may sell in your price range. For complete information and additional soil maps, go to YoungerAuction.com.

TERMS: 10% Down Payment per tract of good faith, non-refundable money to be made on day of sale entering into purchase agreement guaranteeing clear title. Balance is due at closing on or before 30 days. Immediate possession will be given on sale date for spring tillage if so desired upon signing of contract. Escrow to be held at the office of Nodaway Abstract, Maryville, Mo. Property is being sold as is, where is. Statements made at time of auction take precedence over any advertising in print or online, printed documents, or previous statements. YAC, INC d.b.a. Younger Auction Company and its representatives are acting as exclusive agents of the sellers.

Brian and Bernice Burson, Owners

Mark Younger, Auctioneer For complete listings and pictures visit our website
660-541-1977 **WWW.YOUNGERAUCTION.COM**
 Email: yac@youngerauction.com

WARREN COUNTY AUCTION

**Auction Location: American Legion Hall
105 W 1st Ave | Indianola, IA 50125
Friday, February 25th at 10:00 AM**

Peoples Company is honored to represent Jayne and Kent Ruble in the sale of 311.89 surveyed acres located 7 miles southeast of Carlisle, Iowa in Warren County. This farm has what everyone is looking for, high quality tillable farmland, beautiful ponds, and excellent building sites all located .5 miles off hard surface road. The tillable acres are tiled, terraced, and have had dry fertilizer applied by Heartland Coop. The farm will be sold in 5 tracts using buyers choice method of marketing allowing the successful bidder to take their choice of any or all tracts with their high bid.

Tract One - 85.16 Acres M/L | CRS2 87.2
Tract Two - 71.69 Acres M/L | CRS2 78.6
Tract Three - 55.43 Acres M/L | CRS2 73.8
Tract Four - 64.66 Acres M/L
Tract Five - 34.95 Acres M/L



Daran Becker
Daran@PeoplesCompany.com
515.979.3498

PEOPLES COMPANY
INNOVATIVE. REAL ESTATE. SOLUTIONS.

JAMESPORT BUILDERS
660-684-6931
POST FRAME BUILDINGS

Free Estimates

Machine Sheds • Horse Barns • Garages
WE ALSO DO METAL ROOFS, SPRAY FOAM INSULATION (OPEN & CLOSED CELL) & CELLULOSE INSULATION
We Have: House Plans, Dirt Work & Concrete Available
Hours: Mon-Fri 8 AM - 5 PM • Sat By Appointment Only
32137 State Hwy 6 • Jamesport, MO 64648
Serving Southern Iowa



PETS

FOR SALE: Shiba Inu Puppies, APR Registered, Shots, 1 Male, 1 Female, \$150, Born 6-24-21.
641-895-5112 2-11

AG RELATED

FOR SALE: Terrier Puppies, Wormed, First Shots And Vet Checked.
660-956-2961 2-11

AG RELATED

FOR SALE: 2012 JD 1990 CS Air Drill, 35 Ft., 15 Inch Spacing, Low Acres, Purchased New.
641-208-0424 2-25

FOR SALE: 1st And 2nd Cutting Of Alfalfa And Grass Mix Round Bales, Net Wrapped, No Rain, \$70.
515-669-0704 2-18

AUTOMOTIVE

FOR SALE: 2011 Ram 1500 Big Horn, 4x4, Quad Cab, 5.7 V8, Auto Full Power Tow, Sharp, 132K, \$19,000.
641-820-0348 2-18

FOR SALE: 4 BFGoodrich Tires LT285/60R18, 5/32 Tread, \$25 Each, Call.
319-931-3838 2-18

ATTN TRUCK OWNERS: Rhino Linings Offers You The Worlds Number One Sprayed In Truck Bedliner. Also Works On Livestock Tanks, Creep Feeders, Horse Trailers, Etc. Call For An Appointment & More Info.
641-799-5672 TFN

GREAT PYRENEES:

Puppies Ready February 3rd., Parents Guard My Sheep With Zero Predator Issues. Price \$250.00 Firm. 7 Available.
660-988-0569 2-11

REAL ESTATE

HOMES!: 16X80 New Single Wide, 3 Bdr - 2 Bath, \$72,500.

Lincoln Homes Hwy 30 Ogden, IA 50212
lincolnhomesia.com
515-275-2717 TFN

FOR SALE: Big Round Bales Dry Hay Wrapped In Plastic, No Rain, First And Second Cutting, Alfalfa/Clover/Grass Mix, 200 Bales, \$35-\$70 A Bale.
641-722-3002 2-11

FOR SALE: 100 Orchard Grass, 50 Brome, 40 Alfalfa, 100 Straw In Big Square Bales. Also 200 Straw In Big Round Bales. All In Barn Near Cairo, MO. Please Call For Price.
573-470-0077 2-11

PUPPIES, PUPPIES: We Want to Buy Your Puppies! Registered or Mixed Breeds. We Have Homes Waiting for Them!
573-784-9866 TFN

**"One Man's Junk Is Another Man's Treasure!"
Sell It in the Hawkeye!**

FOR SALE: 24 Ft x 5 Ft Free-Standing Cattle Panels, Weighing 600 Lbs Each, Fastener Chains Included. Located in Troy, IA.
641-680-0892 TFN

Virtual Online Auction - Bid @ www.SullivanAuctioneers.com

Marion County, Iowa

LAND AUCTION

TUESDAY, FEBRUARY 22, 2022 @ 10:00 A.M.



77 ACRES± selling in 2 TRACTS

The Clark farm is located in Sections 2 & 10, Washington Township, Marion County, IA (approx. 5 1/2 miles south of the junction of Highways 5/92 and 14 in Knoxville IA.)
Make plans now for this upcoming Marion County, IA land auction. Tract 1 offers highly productive Grundy & Haig soils, is 100% tillable and boasts a CSR2 of 79.8! Tract 2 offers productive tillable farmland, a small amount of recreational acreage and a very usable machinery storage building. We urge you to take a look at these conveniently located farms just south of Knoxville, IA that includes hard surface road frontage.

THE MARJORIE F CLARK REVOCABLE TRUST
Scott Clark - Trustee

Representing Attorney: Michael D. Craver | Craver, Grothe & Cox, LLP
303 W State St, Centerville, IA 52544 | (641) 856-2244

FOR ADDITIONAL INFORMATION, CONTACT AUCTION MANAGERS:
John Probasco (641) 856-7355 & Jim Huff (319) 931-9292

SULLIVAN AUCTIONEERS, LLC • TOLL FREE (844) 847-2161
www.SullivanAuctioneers.com • IL Lic. #444000107

HAWKEYE TRADER

Delivery Drivers Wanted

**Southeast Iowa
Northeast Missouri**

Earn Good Pay For A Few Hours of Delivery Weekly!

**Must Have A Reliable Vehicle!
Must Be Very Dependable!
Good Driving Record Required!**

Call: 641-675-3971

For More Information

CALL TODAY!



2010 Limited

All LED Headlights,
Chrome Forks,
Upgraded Speakers,
Lots of Extras,
38K

NO DOC FEES!

\$12,995

C&C Cycle
Chariton, IA • 888-475-2243
www.cc-cycle.com



VIRTUAL LIVE ONLINE

HOWARD COUNTY, MISSOURI

LAND AUCTION

840± ACRES • 5 TRACTS (Subject to Survey)

TUESDAY, MARCH 8, 2022 AT 1:00 P.M.



Farm is located approximately 0.3 miles south of Armstrong, MO or approximately 10 miles north of Fayette, MO in Sections 33 & 34, T52N•R16W and Sections 3 & 4, T51N•R16W, all in Prairie Township, Howard County, MO.

Farm represents well-maintained highly productive farmland currently in excellent improved pastureland, CRP and row-crop production. Farm offers outstanding hunting & recreational acreage. This is an outstanding opportunity to own a turnkey livestock facility with barns, sorting pens, grain bins, cross-fenced pastures, waterers, well-maintained move-in ready homestead, as well as a historic 2-story home.



**OPEN HOUSE: 1421 Hwy 3, Armstrong, MO 65230
and 1561 Hwy 3, Armstrong, MO 65230**
SATURDAY, FEBRUARY 19TH • 11 AM - 1 PM



HAYHURST FARMS

REPRESENTING ATTORNEY: Rouser Law Office | David Rouser
400 N. Franklin Street | Kirksville, MO 63501 | (660) 665-7515

TITLE WORK: Tri County Land Title Services
104 Professional Pkwy | Troy, MO 63379 | (636) 775-2274

AUCTION MANAGERS:
BILL FRETWELL (660) 341-7735 & JENNIFER WOOD (217) 257-8812

SULLIVAN AUCTIONEERS, LLC • TOLL FREE (844) 847-2161
www.SullivanAuctioneers.com • IL Lic. #444000107



We Now Offer Owens Corning Insulation Blown Into Your Attic!

Keep Your Home Or Shop The Temperature You Want It!

Call Us Today To Schedule Your Appointment!



17893 212th Street • Bloomfield, IA 52537
641-722-3605 • Mon. - Fri. 7 AM - 5 PM



FOR SALE: 1994 Jaguar Vanden Plas XJ6, Maroon, 6 Cyl Auto, Leather, Moonroof, 54K Miles, \$3,000.
641-203-9299 TFN

LIVESTOCK

FOR SALE: 21 Outstanding Simmental And Sim-Angus Cows. Bred To Top Bulls Of The Breed To Start Calving 2-15-22. Average Age Coming 6 Yrs. Preg-Checked In 3rd Stage. Average 1400 lbs. Papers Available. Drake Simmental. Centerville, Iowa.
641-895-9422 2-11

BULLS FOR LEASE: Over 70 Registered Angus & Hereford To Choose From. 90 Day Lease \$900. Trucking Available At Extra Charge. Kingdom City, MO.
573-999-3197 TFN

FOR SALE: Quality Holstein Angus Cross Feeder Calves On Kalmbach Feed, Complete Vaccination Program, Trailer Size Loads, For More Info Or Pictures.
814-229-2401 2-25



'79 Ford F150
400M 4 Spd,
Lift, Big Rubber,
4 Bbl, Headers,
Alum Radiator
LAMBIRTH'S TRUCKS
641-943-2551

We want to purchase & market your grain.



Buyers of Corn and Soybeans.
Organic & Non-GMO Corn and Soybeans.
Contracts Offered • Forward Pricing

Baring Elevator LLC

CONTACT US FOR PRICING
Baring, MO
660.892.4411
baringelevator.com

>> ONLINE ONLY << LAND AUCTION Bloomfield, Iowa

185th and Timber Ave.

79
acres

HIGH QUALITY
RECREATIONAL FARM
WITH INCOME!

- 61 ACRES TILLABLE (RENTED FOR 2022 @ \$200 PER ACRE)
- MULTIPLE HUNTING LOCATIONS
- HARDWOOD TREES
- POTENTIAL BUILDING SITE

online bidding ends:

February 28th

Lynch Boys.com
Auction Service



Download on the App Store

Post Frame Buildings



- Shop Houses
- Metal Roofing
- Free Estimates

NISLEY
CONSTRUCTION

641-203-6663

Quality to Last a Lifetime



Edina Livestock Sales
Edina, Missouri
Weekly Sales Start @ 12:30 PM

Friday, February 11th - Special Feeder Calf Sale
Friday, February 18th - Special Feeder Calf Sale

Watch for upcoming Cow Dispersal

ALL SALES TELEVISED ON DV AUCTION
To Consign For Any or All Sales
or For All Information Call:
Owner - Kevin Strange • Cell: 660-341-9974
Ryan Strange • Cell: 660-341-9721
Sale Barn: 660-397-9999

Field Reps:
Bill Tom Hall 660-342-5420 • Jason Bischel 660-216-0373
Jason Legg 573-822-8847 • John Powell 660-341-1717

Albia Spring Consignment
AUCTION
Saturday, April 2nd, 2022

Taking Consignments for
Farm Machinery, Antiques,
Collectibles & More.

To Consign or For More Information
Call Jake at 641-242-0620

TIMED ONLINE VINTAGE TOY AUCTION
Lots closing on February 20th
Selling vintage and newer GI Joe, Evil Kneivel, Walt Disney, Hot Wheels, Godzilla and many other vintage toys
ALTISERAUCTIONANDAPPRAISAL.HIBID.COM



ATTENTION!

**Agri-Power FFA Alumni Auction is back,
live and in person
at the Eddyville Raceway Park
on March 19!**

We are looking for consignments!

Questions or to consign, please contact:
RJ McGlothlen 641-295-1103
Doug Brinegar 641-777-1664
Jeff Lathen 641-799-0694

**Absolute auction.
Farm or shop related
items only.**





\$15,995

966 IH
New Fenders, Starter, Seat,
LED's, Chrome Stack,
Good Rubber, 3 Pt Dual
Outlets, Dual Hubs, Been
Overhauled, Original Tins

LAMBIRTH'S TRUCKS
641-943-2551

MAST VINYL WINDOWS
THERMO-PRO WINDOWS
Custom Size Is
Our Specialty
Professional
Installation
Available
FREE ESTIMATES
22172 Hwy. 63
Bloomfield, IA 52537
800-206-9949



WOW!

**2013
Wide Glide**
Sissy Bar,
Only 3,000 Miles!

NO DOC FEES! **\$10,995**

C&C Cycle
Chariton, IA • 888-475-2243
www.cc-cycle.com

FARM EQUIPMENT AUCTION
March 12, 2022 @ 10:00 AM
29274 Highway 63 • LaPlata, MO 63549

This will be a large auction with 2 rings running most of the day, so please come prepared.

Tractors, Trucks, Trailers, Construction and Farm Equipment will be sold live and online beginning at noon.

scottysauctionservice.com
James West III Estate



New Harleys
3.29% For 66 Months
And \$0 Down With
Qualified Credit!
Call Us Before You Buy!
NO DOC FEES!

C&C Cycle
Chariton, IA • 888-475-2243
www.cc-cycle.com

ONLINE - ONLY
AUCTION

BIDDING OPENS: WEDNESDAY, FEBRUARY 16
BIDDING CLOSES: THURSDAY, MARCH 3

Vintage & Antique Furniture - Household Goods - Costume Jewelry - Quilts - Advertising Items including Middlekoop's Hybrid Seed Corn Lighter - Wood Crates - China Doll - Antique Tourist Books & other vintage books - Antique Trunk - Antique Shoe Molds & much more!

View <https://greinerrealestate.hibid.com/auctions/> to register bid, bid, and view full terms of auction.

Location: 106 E South St, Richland, IA 52585
Open House: Saturday, Feb 26, 1-3 pm - Pickup: Sat, March 5, 1-5 pm

BETTY RUTH FRITCHEN, OWNER- US BANK, CONSERVATOR

www.greinerrealestate.com

Auctioneer: Myron Greiner, 319-694-4522

Greiner Real Estate & Auction LLC, Richland, Iowa—Licensed in Iowa
All announcements made on bidding site take precedence over previous advertising. Information is believed to be accurate however buyers should verify information to their satisfaction. Complete list of terms can be found on bidding site.

2022 Spring Consignment Auction
CONSIGNMENTS WANTED!!
Saturday, March 19th • 9:30 AM
POWESHIEK COUNTY FAIRGROUNDS!
425 East St. S • Grinnell, Iowa

Farm & Livestock Equipment, Construction Equipment, Trucks and Trailers, Vehicles, Lawn and Garden Equipment Wanted!!

Live and online bidding available!

Online Bidding & Catalog Available at www.equipmentfacts.com

Call Auctioneer **Ryan Iverson** to discuss your consignments!
641-325-1174

IVERSON
AUCTION COMPANY

Ryan & Katie Iverson
Grinnell, IA

TRACTORS & EQUIPMENT AUCTION
SAT. FEB. 19 • 10 AM
3032 WASHINGTON DR
HAMILTON, MO

We will hold an Auction at the Farm North of Hamilton, MO - Driving on Hwy 13 on the North Edge of Hamilton, turn East on Putnam Drive which becomes Washington Drive & continue to 3032 Washington Drive. Auction Signs Posted **PLEASE BE ON TIME** We have decided to sell our 20 year Collection of Tractors, Equipment, Parts, Weights & Related Items. Also selling Five Saddles & Tack, Small Harness, Miller TIG Welder & Much More. **PARTIAL LISTING.**

TRACTORS Allis Chalmers G Tractor & Implements John Deere 60 Tractor Farmall 400 Tractor Two H Farmall Tractors M Farmall / C Farmall 18 Allis Chalmers Tractors including WC & WD Allis Chalmers CA Two Allis Chalmers C Tractors Three Allis Chalmers UC Tractors Allis Chalmers U Tractor 1938 Allis Chalmers B Tractor on Steel Case VAC Tractor Farmall Regular Tractor on Steel	TRACTORS 1949 Allis Chalmers W.D. Pulling Tractor with 460 Cu. Inch Engine - Won a lot of Trophies. Offered with Reasonable Reserve. Allis Chalmers HD6 Dozer - Needs Piston & Put Together Some Run & Some Do Not -- Please Call Owner (816) 284-1109 For Full Details.	Four Massey Harris 44 Tractors 1949 Allis Chalmers W.D. Pulling Tractor with 460 Cu. Inch Engine - Won a lot of Trophies. Offered with Reasonable Reserve. Allis Chalmers HD6 Dozer - Needs Piston & Put Together Some Run & Some Do Not -- Please Call Owner (816) 284-1109 For Full Details.	Two ATV Spray Tanks 15 & 25 Gal. Four ATV Tires 500 Gal. Propane Tank Semi Trailer Suitable for Storage PARTS & WEIGHTS Large Number of Tractor Weights (including 30 - IH 100 Pound Weights) 9 Bolt Hubs & Leroy Manifold Two 262 Motors / Two D-17 Motors Two Transmission Blankets Two Crystal Motors Carburetors, Starters, Fenders, Small & Large Parts Motor Stand - Sand Blaster Tires & Wheels
---	---	--	--

EQUIPMENT
JD 13 Hole Mechanical Lift Drill
Ford 501 - 7' Mower
AC 7' Pull Mower / JD 1240 Planter
AC Two Row Cultivator
AC - 2,3 & 4 Bottom Plows

2012
GL1800
Gold Wing
w/Motor Trike
Independent Suspension,
31K Miles, Just In!

NO DOC FEES! **\$22,995**

C&C Cycle
Chariton, IA • 888-475-2243
www.cc-cycle.com

TAMA LIVESTOCK AUCTION
641-484-3465

Fed Cattle, Slaughter Cows & Bulls
Every Wednesday at 9:00 am

SPECIAL PRE-CONDITIONED CATTLE SALE
Friday, February 18, 2022 - 11:00 AM

SPECIAL BRED COW, HEIFER & FEEDER SALE
Monday, February 21, 2022 - 11:00 AM

For Markets & Listings go to
www.tamalivestock.com

FOR SALE
Driveway Fabric Rolls
Commercial, Heavy Duty
Designed for Heavy Traffic
12'5" Wide • 432' Long

\$370.00/Roll
660-216-0938

TYSON & GAYLA MILLIGAN • 816-284-1109

Pictures on Website - www.PickettAuction.com

EDDIE PICKETT AUCTION SERVICE, INC.
816-632-0700 • TRENT MUMM • 660-238-3960
WWW.PICKETTAUCTION.COM

TERMS: Cash or Valid Check. Not Responsible for Accidents, Thefts or Errors in Advertising. Announcements made at Auction take Precedence over Printed Ads.



911 HEAD LAST WEEK | EXPECTING 1400 THIS WEEK

OSBORN
LIVESTOCK AUCTION
Located 7 miles West of Cameron on
HWY. 36, OSBORN, MO

Barn Phone: (816) 675-2424
Danny (816) 649-8485
Transportation and Order Buying Available • Bonded • Insured

SALE EVERY WEDNESDAY | 10:00 a.m

STEERS	HEIFERS
300#\$2.07\$1.73	400#\$1.96\$1.66
400#\$1.96\$1.66	500#\$1.82\$1.53
500#\$1.82\$1.53	600#\$1.71(Potload 667) \$1.52
600#\$1.71(Potload 667) \$1.52	700#\$1.66\$1.45
700#\$1.66\$1.45	800#\$1.54\$1.41
800#\$1.54\$1.41	900#\$1.46\$1.30
900#\$1.46\$1.30	1000#\$1.41\$1.25
1000#\$1.41\$1.25	1100# Fats\$1.23\$1.20
1100# Fats\$1.23\$1.20	

Top Cow: \$0.87 - Cameron Holsteins & Longhorns: \$0.51-\$0.88
Top Bull: \$1.05 - Richmond Longhorn X & Dairy X: \$0.89-\$1.20

• 3 COW DISPERSALS WEEKLY •

Buying Butcher Cows & Horses Daily
We Have 9 Butcher Cow Plants Represented

RECEIVING HOURS: Daily until sale time

Owner, Jayme Walker 816-665-4277 Randy Vanderkooi, Fieldman 816-632-0694	Dale Coble, Fieldman 816-213-3581 Brandon Eichied, Fieldman 660-973-3044
Ivan Kanak, Fieldman 816-724-1043 Frank Peterson, Fieldman 660-247-2306	Gary Mann, Fieldman 816-294-5849 Bill Bray, Fieldman 816-724-0438 Gary Jackson, Fieldman 816-724-4348

SIMULCAST AUCTION
221.87± Acres • Jasper County, Iowa

Farmers National Company L-2200160

Live Event: Tuesday, March 8, 2022 at 10:00 AM

American Legion
103 East Marion Street • Monroe, Iowa

ONLINE SIMULCAST BIDDING: Bidding starts Monday, March 7, 2022 at 8:00 AM
Bidding ends Tuesday, March 8, 2022 at close of live event
To Register and Bid on this Auction, go to: www.FNCBid.com

-- Quality cropland southeast of Prairie City with CSR2 of 71 --
-- 100% of the 2022 cash rent to the Buyer --

For more information on property details, please contact:
John & Kathy Van Zee, Agents • Mitchellville, Iowa
Phone: (641) 521-0151 or (641) 521-5305
JVanZee@FarmersNational.com • www.FarmersNational.com/JohnVanZee
Eric Van Zee, Agent • Colfax, Iowa
Phone: (515) 971-2633
EVanZee@FarmersNational.com • www.FarmersNational.com/EricVanZee

www.FarmersNational.com
Real Estate Sales • Auctions • Farm and Ranch Management • Consultation
Appraisals and Valuations • Insurance • Oil, Gas, and Renewable Energy Management
Forest Resource Management • National Hunting Leases • FNC Ag Stock

High Spring Machinery & Livestock Equipment
Consignment Auction

Location: Downing, Missouri, take Hwy 136 West 1 mile to auction site.

Friday, March 25, 2022
@ 9:00 a.m.

CONSIGN NOW!

No additional hay racks items.
Advertising deadline March 1.

to consign items contact 660.342.8634

ANTIQUE & TOY TRACTOR AUCTION
February 19th • 10 am
2705 MAIN ST. • UNIONVILLE, MO

Antiques: Peace dollars, silver half dollars, International Harvester bolt bin, IH banners, tractor books, toys, Kirksville Mo MFA cream can, other cream cans, Penzoi rocker can, metal lawn chairs, garden plows, boxes of ammo, beer advertising lights, 2 table top coffee grinders, Pepsi clock and thermometer, gas cans, coal hods, boxes of unopened baseball cards, post vice, pressure canner, Union special sewing machine, traps, street signs, advertising trays, steel wheels, miner lamp, wood barrel, nail kegs, Aladdin lamps, oil lamps, buggy seat on springs, Collins cast iron tractor tool box, belt buckle collection, gold rim glasses, straight razors, several hen on nest, 2 gallon churn, several chicken water crocks, clocks, blue band water cooler crocks, canning jar crocks, cow skull with horns, lots of cast iron pans, marbles, cream separator, scales, several old handsaws, hand tools, axes, license plates, tractor seat, cast iron and galvanized boilers, well pulley, galvanized items, barn lanterns, piano stools. **Toy Tractors:** Tractors and toys will sell after all antiques so somewhere close to 1:00. Most are 1/16 scale. Boxed tractors include, Oliver 3 beauties 66 77 88 both 1 and 2 wheel, Case 7120, deluxe spreader, JD stock 584 #501, JD M Farmall 300 350 F20, JD 430 crawler, 2 IH 1586 w/ cab/Oliver row crop 77, Hesston 980, 1380, 2 AC roto balers, Case 600, JD 60 orchard, 3 JD 6400 row crop, roller disc, 2 JD 630 LP, JD grain drill, Deutz 6240, IH spreader, IH corn picker, IH ariel flow combine, IH 600, Fordson, Spirit of Oliver, Cockshutt 770, AC LP w/ 254 mower, JD 5020 diesel, Arnold Palmer golf course tractor, Elvis Presley International 300, AC precision D17 w/ picker, MF 135, challenger, JD 4020 w/ loader, AC WD45 w/ umbrella, international cub, small Ford and JD pedal tractors, JD GP, G, M, R, A with man, JD precision 420 w/ disc, JD 12A combine, JD precision 720 w/ 80 blade and 45 loader, Oliver 1950, Farmall 450, JD 520 and 620 set, JD precision lawn and garden. No box to include several older no number tractors and implements, JD 6600 combine, JD skidder, IH 1256, 1206, 806, 350, 886, 3 JD center pivot tractors, International M highway dept, JD baler, JD 5020, AC 7050 with purple motor, Case 3294 2594, Ford 4600, 8600, TW 25. Several boxes of parts tractors, several True scale toys, 2 pedal cars, Caterpillar wind up tin toy, fire trucks, Texaco trucks, several Tonka toys, hot wheels, semis, some in boxes.

Indoor sit-down style auction in a heated building.
Preview from 2 to 5 pm on February 18th.
Food and restrooms available.
Check out pictures on our Facebook page.

ALTISER
AUCTION APPRAISAL
KRIS ALTISER
660-626-4960



ANGELA OWEN

Missouri: Linn, Livingston, Mercer, Daviess, Grundy, Dekalb & Harrison Counties

660-216-0724



KATIE MITCHELL

Iowa: Des Moines, Henry, Jefferson, Lee, Louisa, Keokuk, Washington & Van Buren Counties.
In Illinois: Hancock & Henderson Counties

319-470-0251



LADD MONTEGNA

Iowa: Appanoose, Polk, Jasper, Mahaska, Marion & Lucas Counties

641-891-7254



STAN MASON

Iowa: Polk, Dallas, Guthrie, Audubon, Cass, Adair, Madison, Warren, Montgomery, Adams, Union, Clarke, Lucas, Page, Taylor, Ringgold, Wayne & Decatur Counties

515-205-0921



WENDY HOPKINS

Missouri: Adair, Putnam, Scotland & Schuyler Counties

641-777-9139

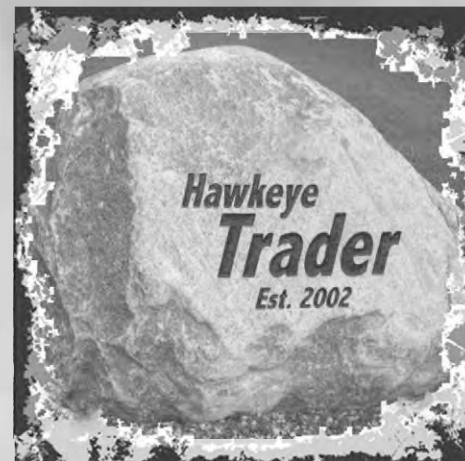

*Hawkeye
Trader*
Est. 2002

OFFICE

Iowa: Boone, Greene, Grundy, Hamilton, Hardin, Marshall, Polk, Story, Tama & Webster Counties, Davis, Wapello, Monroe & Mahaska (Oskaloosa) Counties

641-675-3971

**We Go Along Way To Serve You!
Call One of Our Friendly Helpful Sales Reps!!**

Visit Our Website:

www.hawkeyetrader.com

T YOUR **TRADER**

Cut-to-Length Metal for Roofing Siding & Trim

Buy Direct
Snap Lock Standing Seam Roofing Rolled On Site
Interior Liner Steel



AFFORDABLE METAL
MANUFACTURING
563-264-8212

303 Cleveland St
Muscatine, IA 52761
Email: amminfo7@gmail.com
www.affordablemetalmfg.com

Where Quality and Affordability Meet



AVAILABLE STOCK

MOBILE HOMES

Immediately, Double Wide And Single, 3 And 4 Bedroom
573-499-9993
www.columbiadiscounthomes.com



\$3,995

1999 Ford Ranger

Stepside, XLT, 4 Cyl, 5 Speed, Air, New Tires & Brakes

LAMBIRTH'S TRUCKS
641-943-2551

MISC

BUILDING MATERIALS FOR SALE: 2X4'S, Half Inch Plywood And OSB. 515-290-2901 2-25

INSTALLING: Metal And Shingle Roof. Serving The Tri-State Area, Call For Free Quote. 660-730-0233 2-18

FOR SALE: USED STEEL PIPE 2 Inch To 48 Inch Diameter, Located Carrollton, MO. For Details Call Redmount Midstream LLC. 660-542-3000 2-25

FOR SALE: Used (47) 50 Ft. Trusses; 120 Sheets Of 27 Ft. Long Steel Siding/ Roofing Panels; 140 Sheets 20 Ft. Long X 3 Ft. Wide Corrugated Plastic Ceiling Panels; (200) 20 Ft. 2x4's. Best Offer. 641-660-6838 2-18

CUSTOM LOG SLABBING SERVICES: No Log is Too Big! Maximum Log Capacity 90 Inches Diameter by 27 Foot Long. Jaguar Lumber 641-664-2080 TFN

ZIMMERMAN'S STORE

Main Street • Rutledge, MO • 660-883-5766

FEBRUARY SALE

10% - 30% OFF SHELF PRICE
NOW FOODS PRODUCTS

Supplements, Essential Oils, Diffusers, Health Care & Food Items

SALE 20%- 30% Off

Green Hills Dairy Raw Milk Cheddar
Locally Made - Edina, MO.

U.S. No. 1 Russet Potatoes, 10 Lbs.....\$3.79

Apples by the Bushel or by the Pound
Red Delicious, Jonathan, Gala, Fuji, Cortland & Mutsu

Special Price - Seventh Generation Sensitive Laundry Liquid
22 Loads..... Only \$4.89
64 Oz Clear or Lemon Scented Ammonia..... Only \$1.59

22 30 USED BIG TWIN HARLEY'S \$5995-\$9995 ALL NICE BIKES!!!

C&C Cycle
Chariton, IA • 888-475-2243
www.cc-cycle.com

SAM'S AUTO SALES

319-204-5214

www.samsautosalesia.com

Please See Our Website for Our Repairable Vehicles!



CLEAN TITLE

2014 DODGE RAM 3500 BIG HORN
4x4, 4 Dr Crew Cab, 8 Ft LB, SRW, 6.7 Turbocharger, Diesel, 175,301 Miles
\$32,800



READY TO GO

2015 CHEVROLET SILVERADO 3500HD LT
4x4, 4 Dr Crew Cab, SRW, Auto, 6 Spd, 6.6L V8 Turbocharger, Diesel, 135,000 Miles
\$40,000



READY TO GO

2018 NISSAN FRONTIER PRO4X
4x4, 4 Dr Crew Cab, 5 Ft SB, 5A 4.0L V6, Auto, 5 Spd, 37,177 Miles
\$24,800



CLEAN TITLE

2015 FORD MUSTANG
2 Dr Convertible, 3.7L V6, Gasoline, RWD, 75,980 Miles
\$18,500



CLEAN TITLE

2017 RAM 2500 ST TRADESMAN
4x4, 4 Dr. Crew Cab, 6.3 Ft SB, Auto, 6.4L V8 Gasoline, 122,997 Miles
\$26,000



READY TO GO

2014 CHEVROLET SILVERADO 2500HD LT
4x4, 4 Dr Crew Cab, SB, 6.6L V8, Turbocharger, Diesel, Auto, 6 Spd, 249,590 Miles
\$22,000



CLEAN TITLE

2018 GMC SIERRA 1500 SLT
4x4, 4 Dr Crew Cab, 5.8 Ft SB, Auto, 8 Spd, 5.3L V8, 82,051 Miles, One Owner
\$35,500



READY TO GO

2015 JEEP GRAND CHEROKEE LIMITED
4x4, 4 Dr SUV, Auto, 8 Spd 3.6L V6, Gas, 92,881 Miles
\$17,500



CLEAN TITLE

2013 JEEP WRANGLER UNLIMITED SAHARA
4x4, 4 Dr SUV, Auto, 5 Spd, 3.6L V6, Gas, 150,928 Miles
\$24,800



READY TO GO

2014 JEEP WRANGLER UNLIMITED RUBICON
4x4, 4 Dr SUV, 3.6L V6, Gasoline, Manual, 6 Spd, 72,608 Miles
\$24,500



READY TO GO

2019 FORD RANGER LARIAT
4x4, 4 Dr Super Crew, 5.1 Ft SB, 2.3L Turbocharger, Gas, 13,537 Miles
\$32,500



READY TO GO

2017 NISSAN TITAN XD SL
4x4, 4 Dr Crew Cab, 5.0L V8 Turbocharger, Diesel, Auto, 6 Spd, 62,922 Miles
\$31,500

Mt. Pleasant, IA • 803 East Winfield Ave • NOT RESPONSIBLE FOR TYPOGRAPHICAL ERRORS

Attention

Machinery Wanted

Advertising Deadline: Items Must Be On Lot By Monday, February 28, 2022

Auction Lot Located on Hwy 3 ~ 401 1/2 East Elm Pocahontas, IA (The Big Red Shed)



BUY, SELL, TRADE: Gold, Silver, Jewelry, Coins, Pocket Watches, Indian Artifacts, Bullion, Black Powder, Antique Firearms, Proof Mint Sets, National Bank Notes, \$500 & \$1,000 Bills. McKee Coins 641-684-6006 2-11

DO YOU NEED SOME BEES?: We Are Taking Orders For Package Bees Until The End Of Feb. Open 3 Days A Week. Mon, Fri, Sat. Shady Lane Bee Supplies 5485 St. Hwy M Moberly, MO 65270 2-17

TIMBER MANAGEMENT: Buying Standing Timber. Bonded & Insured. PAID IN FULL PRIOR to HARVESTING. Specializing In Walnut - Oak - Maple. Cole. 641-895-8209 12-31-22

MCKEE COINS INC: 213 East Main Street, Ottumwa, IA 52501. http://mckeecoins.com. Specializing in Coin Auctions, Gold, Silver & Bullion. 641-684-6006 2-11

SCOTT HUSKEY'S HOME SERVICE!!: Insulated Skirting for Manufactured or Older Site Built Homes. Eliminates Frozen Water Lines & Cold Floors. Save 20 to 25% on Utility Costs. I Also Have an Uninsulated Heavy Duty Vinyl Skirting-Looks Great! Since 1972 573-696-3468 TFN

Auction Date:

Wednesday ~ March 9, 2022 @ 8:30 AM

Wanted: Tractors * Planters * Sprayers * Skidloaders * Tillage Equipment * Combines * Heads * Trucks * Trailers * Construction Equipment *

Website: salebarn.ncn.net

Rick & Kendra Winegarden ~ Owners ~ 712-335-3117

Cell ~ 712-358-0974 Email ~ salebarn@evertek.net

Online Bidding Provided By Equipmentfacts

Pocahontas Machinery Auction

Looking to Sell Your Farm or Construction Equipment?

- All Makes and models - Loader Tractors, MFWD Tractors, 2wd Tractors, 4wd Tractors
- Kinze Planters - Split row & 30" planters
- Later Model John Deere & CIH Platforms, Corn heads
- Grain Carts
- Combines, 90s models and newer
- Skid Steers
- Excavators
- Wheel Loaders

One piece or a whole line of farm or construction equipment; Let us know what you have.

Shay 660-605-0839 Justin 660-605-2346

BandSequipmentsales.com
GALLATIN | MISSOURI

KARS, INC

www.karsincdsm.com

ON EUCLID

As for DeMarcus

2000 E. Euclid
Des Moines, IA
515-265-0215



2011 Chevy HHR LT
4 Cyl, Auto, Full Power, CD, Keyless Entry, Only 59K
\$11,995



2012 Chevy Avalanche LTZ
4x4, 5.3 V8, Auto, Loaded, Heated Leather, Sunroof, 143K Miles
\$20,995



2011 Buick Enclave CXL
AWD, V6, Leather, Sunroof, 3rd Row Seating, MP3, 120K
\$12,995



2012 Dodge Charger Police
5.7 Hemi, Auto, Full Power, Keyless Start & Entry, 141K
\$10,995



2015 Cadillac ESV Platinum
4WD, 6.2 V8, Fully Loaded w/Leather, 3rd Row Seating, 154K
\$30,995



2014 Buick Encore Convenience
AWD, 4 Cyl, Full Power, 82K
\$15,995



2004 Honda Element EX
4WD, Nicely Equipped, 118K
\$9,995



2009 Ford F150 Super Crew
4x4, 5.4 V8, Platinum, Full Power, Leather, Sunroof, 133K
\$19,995



2011 GMC Acadia Denali
AWD, V6, Full Power, Leather, 3rd Row Seating, 106K
\$15,995



2015 Chrysler 200 Limited
Keyless Entry & Start 156K
\$10,495



2010 Chevy Tahoe LT
4WD, 5.3 V8, Full Power, Leather, Sunroof, 99K
\$17,995



2009 Chevy Traverse LT
AWD, V6, Full Power, 3rd Row Seating, 169K
\$6,995



2011 Mercedes-Benz C-Class C300
4Matic, V6, All Wheel Drive, Loaded, Leather, Sunroof, 102K
\$11,995



2005 Chevy Silverado K2500HD
6.0 V8, Auto, Air, Regular Cab, 165K
\$8,995



2011 Ram 1500 Big Horn
4x4, Quad Cab, 5.7 V8, Auto, Full Power, SHARP!! 161K
\$21,995

Virtual Online Auction - Bid @ www.SullivanAuctioneers.com

Marion County, Iowa

LAND AUCTION

319.10 TAXABLE ACRES
3 TRACTS

TUESDAY, FEBRUARY 22, 2022 @ 1:00 P.M.



The Honey Creek Farms LC property is located in Sections 16, 17, 19, 20 & 21, Knoxville S Township, Marion County, IA. (3 1/2 miles southwest of Knoxville, IA.)

These farms offer productive tillable farmland, income producing CRP and awesome recreational acreage. All tracts sell with full farming rights for the upcoming 2022 crop year. We look forward to your participation in this auction.

HONEY CREEK FARMS LC
David M. Marlenee | Steven R. & Marilyn Smith
Representing Attorney: Christopher S. Talcott | Dentons Davis Brown
215 10th St #1300, Des Moines, IA 50309 | (515) 288-2500

FOR ADDITIONAL INFORMATION, CONTACT AUCTION MANAGERS:
John Probasco (641) 856-7355 & Jim Huff (319) 931-9292

SULLIVAN AUCTIONEERS, LLC • TOLL FREE (844) 847-2161
www.SullivanAuctioneers.com • IL Lic. #444000107



OK CORRALS
One with Wheel Kit
One with Wheel/Door Kit

At **KJ Trailer & Ranch Equipment Sales LLC**
Kelly Kiefer - 641-344-6735

Hwy 2 West • Corydon, IA • 641-344-6735

ANOTHER HILPIPRE AUCTION
TILING CONTRACTOR
E&B TILING, LLC
2206 OLD 6 ROAD • VICTOR, IA 52347
WED., MARCH 16 – 10:00 AM
OFFERING BOTH LIVE ONSITE AND LIVE WEBCAST BIDDING
SHORT SELLING TIME – DON'T BE LATE!!

AUCTIONEERS NOTE: Equipment is ready to go to Work!!
FOR VIEWING: Must make an appointment. Contact Blake Kuesel – Cell: 319-430-0447



TILING MACHINE: Samsons 3700RS, One Owner / EXCAVATOR: Sany SY235C IC, One owner / (2) DOZERS: Caterpillar D7R; Caterpillar D6M / TRACTOR: John Deere 5525, w/542 loader, One Owner / SCRAPERS: Case 9380 Quadtrack tractor; Icon 3610 dirt / COMPACTION: (2) Sheeps foot / AIR COMPRESSOR: Portable, PDS1855, diesel / TRUCK TRACTOR: Freightliner, Detroit 60 Series / (2) DUMP TRUCKS: Freightliner; Ford / TRAILERS: Trailking lowboy, detach; PJ dump; (2) Portable fuel; (3) Tile trailers.

TERMS: Everything sells like is, as is, where is. No warranties or guarantees are in effect whether expressed or implied. All Sales Final. Payment: Cash, Good Check accompanied with letter or credit, or Credit card with an additional fee. BUYERS' PREMIUM of 6% for all onsite purchases and 9% for all webcast purchases.

CONTINUE TO WATCH OUR WEBSITE - www.hilpipre.com

HILPIPRE AUCTION CO.
Waterloo, IA
PH: 319-235-6007 or MERV'S CELL: 319-415-0816





Progress **Through Testing** DEPPE ANGUS

BULL & FEMALE SALE

Friday, February 25, 2022 | 6:30 PM CST

68 Bulls and 44 Pairs & Breds, 15 Open Heifers and 2 IVF Cycles
Video Auction at the Farm near Bloomfield, IA [Heated Sale Facility]
Sale located at 24589 Ebony Ave. Bloomfield, IA 52537



Over 40 Calving Ease Bulls Sell!

PERFORMANCE TESTED GENETICS
COMMERCIAL CATTLEMAN FOCUSED

Dennis, Jennifer, Julia & Jaden Deppe • Waverly, IA
Dennis [call/text], 319-239-1824 / deppeangus@yahoo.com
Andy Joos, Cooperator. 641-777-4949 • Bloomfield, IA
Sale managed by Ruble Cattle Services
Jeremie Ruble. 406-581-7940 / www.rublecattleservices.com

ANGUSGS BID ONLINE AT DVAAuction
Powered by Nexgen GenScan Broadcasting Real-Time Auctions

Deppe Angus Request a sale catalog today!
deppeangus.com

PUTNEY AUCTION SERVICE
VEHICLES, TOOLS, HOUSEHOLD, PRIMITIVES, LAWN & GARDEN, ANTIQUES, FURNITURE AND MUCH MORE!!
ONLINE AUCTION
ONLINE BIDDING ENDS FEBRUARY 19TH, 2022 • STARTING AT 4PM SOFT CLOSE
2612 W. 2nd Ave. (Hwy 92 West) • Indianola, IA 50125
Bid today @ www.putneyauction.com



Stop by Saturday the Feb. 19th from 9am to 4pm for viewing.
Pickup Sunday Feb 20th 9AM to 4PM-One Day Only.
Shipping is available

Putney Auction Service
Mark Putney - Auctioneer
2612 W 2nd Ave (Hwy 92 West)
Indianola, IA 50125
Cell 515-249-3676 • Office 515-961-4124

View Photos online @ www.putneyauction.com & www.auctionzip.com

LIKE US on Facebook: **Putney Auction Service**



WHITETAIL PROPERTIES REAL ESTATE

HUNTING | RANCH | FARM | TIMBER

WE SELL LAND

Jasper Co, IA - 160 +/- acres, Located about 30 minutes from the greater Des Moines area, this property offers CRP income, a great mixture of habitat with hardwoods, water sources, and thick draws to bring the deer in. \$900,000

Keokuk Co, IA - 4 +/- acres. This beautiful brick ranch and acreage should check every box for a top-shelf acreage in the Southeast Iowa country. **SOLD**

Keokuk Co, IA - 30 +/- acres. Excellent return on investment through CRP, while offering hunting and a building site near the Skunk River. **SOLD**

Keokuk Co, IA - 80 +/- acres. This property will offer excellent hunting and a nice income for the owner. **SOLD**

Keokuk Co, IA - 140 +/- acres. Timbered property situated on the north bank of the South River offering recreation, income, and a secluded hilltop building site. **SOLD**

Mahaska Co, IA - 80 +/- acres. This nice farm along a paved road includes tillable acres that can be customized into your own needs. **PENDING**

Tama Co, IA - 113.75 +/- acres. This property offers recreation and investment income on this pheasant country in central Iowa. **SOLD**

Washington Co, IA - 25 +/- acres, This property is great for someone who wants to build a house in the country and have a small farm. \$200,000

Washington Co, IA - 16.1 +/- acres, Located along beautiful Socum Ridge Road lies this property acreage with a significantly remodeled ranch, great views, and excellent hunting timber. **SOLD**

Washington Co, IA - 112.5 +/- acres, This all-timber getaway is secluded and quiet. With a great view and escape from town, or a quality hunting property, this is a great property being here year-round. **SOLD**

Washington Co, IA - 5 +/- acres. Enjoy the benefits of land ownership on this little slice of pheasant country, secluded in the middle of a big deer country. **SOLD**

Washington Co, IA - 31.56 +/- acres. This beautiful property is going to be a top shelf property for anyone who wants to live in the country, have ponds, and not deal with gravel dust. **SOLD**

Clarke Co, IA - 360 +/- acres. This property has great genetics and has produced some B&C trophy deer in the recent years. **SOLD**

Decatur Co, IA - 39 +/- acres, This 39-acre rec property offers a lot of great opportunities. It has cover, south-facing slopes, and open ridges for great food plot opportunities. \$193,050

Decatur Co, IA - 40 +/- acres, This property has beautiful views with a 1.5-acre pond and a great build site that has power and fiber optic at the road. \$200,000

Decatur Co, IA - 163 +/- acres, This powerhouse rec farm offers a great building site, a mix of hardwood timber and has 1 pond on the property. \$815,000

Decatur Co, IA - 240 +/- acres. This combo farm has many great features from the property including food plots to a stocked pond. **PENDING**

Lucas Co, IA - 175 +/- acres. The property features include great access to any part of the property and building site for a home or cabin. **SOLD**

Madison Co, IA - 23 +/- acres, This small tract has a lot to offer with a building site, beautiful hardwood timber ridges, tillable acres, and great hunting. \$225,000

Marion Co, IA - 1 +/- acres. This property is located in an area known for great hunting. **PENDING**

Marion Co, IA - 164 +/- acres. This all-around rec tract is loaded with deer and turkey, has a pond, and is stocked and is located 10 minutes from Dubuque. **SOLD**

Ringgold Co, IA - 39 +/- acres. This property will offer excellent hunting and a nice income for the next owner. **SOLD**

Warren Co, IA - 20 +/- acres. This 20-acre property has a great build site with all the amenities located right off of County Highway 52. **PENDING**

Wayne Co, IA - 137 +/- acres. This incredibly tillable tract is located along highway 20 in a great neighborhood. **PENDING**

Wayne Co, IA - 112 +/- acres. The farm features include a custom-built home, large sheds, and +/- 93 tillable acres. **SOLD**

Appanoose Co, IA - 80 +/- acres. This farm is very well kept and has a proven history of producing trophy deer. The most discerning buyer is going to realize that this is a special place! **SOLD**

Henry Co, IA - 12 +/- acres. This property offers a building site, creek, and pond. **PENDING**

Iowa Co, IA - 188 +/- acres. Very diverse property with wetlands, creeks, upland cover, and more. **SOLD**

Jasper Co, IA - 43 +/- acres. This recreational and hunting tract along the Skunk River Valley is a well-known river corridor in Iowa to hunt big whitetails. **SOLD**

Jefferson Co, IA - 13 +/- acres. Here is an opportunity to buy a new home on a beautiful farm. **PENDING**

Jefferson Co, IA - 242 +/- acres. This well-kept combination farm features 83 tillable acres, a pond, and more. **PENDING**

Jefferson Co, IA - 5.7 +/- acres. Small high quality tillable tract with development potential. **SOLD**

Jefferson Co, IA - 1009 +/- acres. This massive farm near the Jefferson/Van Buren/Herbert line is in the early stages of becoming an elite trophy hunting property with great income. **SOLD**

Louisa Co, IA - 200 +/- acres. This farm represents an ideal blend of agriculture and hunting. **PENDING**

Louisa Co, IA - 540 +/- acres. With two miles of Iowa River frontage, building potential, and a great view. **SOLD**

Monroe Co, IA - 626 +/- acres, We are honored to bring to the market this world-class property, one of the most desirable trophy-hunting properties in the entire state of Iowa. **PENDING**

Wapello Co, IA - 40 +/- acres. This sharn home built for comfort and entertaining is nestled in the heart of Iowa deer country. **SOLD**



BEN HARSHYNE
Licensed in Iowa
(319) 853-1162



GABE ADAIR
Licensed in Iowa
(515) 971-8182



RICH BAUGH
Licensed in IA, IL & MO
(319) 750-9273

TO VIEW THESE PROPERTIES AND HUNDREDS MORE GO TO

WHITETAILPROPERTIES.COM



Whitetail Properties Real Estate, LLC DBA Whitetail Properties, DBA Whitetail Properties Real Estate, in the States of Nebraska & North Dakota DBA Whitetail Trophy Properties Real Estate LLC. Licensed in CO, MN, ND, SD, TN & WI - Jeff Evans, Broker. Licensed in FL, KS, MO, OH & PA - Jefferson Kirk Gilbert, Broker. Licensed in TX & NM - Joey Bellington, Broker. Licensed in IN - Bill Minor, Broker. Licensed in AL, GA, IA, & MS - Sybil Stewart, Broker. Licensed in TN - Tim Burnette, Broker. Licensed in TN - David Pritchard, Broker. Licensed in AR - Anthony Chrisco, Broker. Licensed in NC, SC, VA - Chip Camp, Broker. Licensed in IA, MO - Richard E. Baugh, Broker. Licensed in MI - Edmund Joel Nogaski, Broker. Licensed in IL, MO, WV - Debbie S. Lutz, Broker. Licensed in ID, MT, OR, UT, WA, & WY - Aaron Miliken, Broker. Licensed in KY - John Myers, Real Estate Broker. Licensed in OK - Dean Anderson, Broker. Licensed in KY - Derek Fisher, Broker. Licensed in OH - Jeremy Schaefer, Principal Broker. Licensed in ME - Jason Schendel, Broker.

